

# ME-I SERIES MICROPHONE INPUT MODULES

## ME-I: UK Version

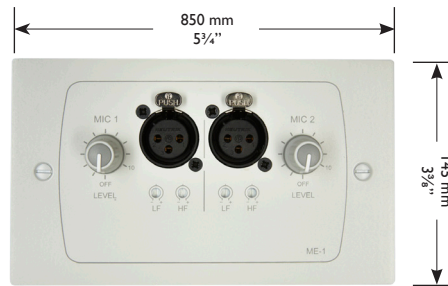

ME-1B



ME-1W

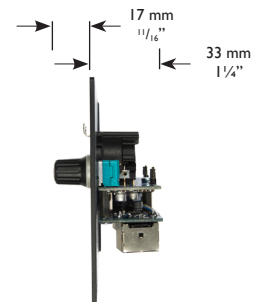

ME-1 side view

## ME-I: US Version



ME-1AB

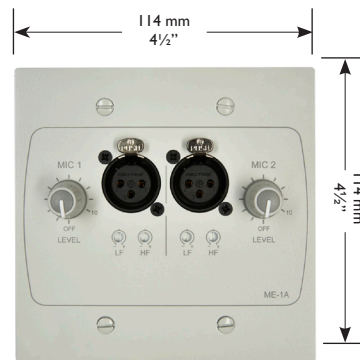

ME-1AW

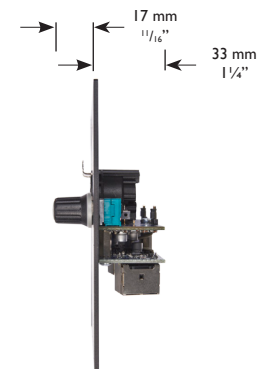

ME-1A side view

## ME-I: Euro-module Version



ME-1MB



ME-1MW

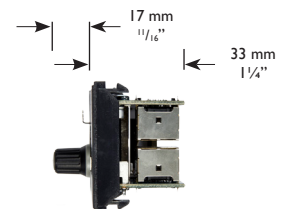

ME-1M side view

## General Description

The ME-I Series is a range of remote microphone input modules for use with the Cloud DCM1 range of Digitally Controlled Zone Mixers (see separate datasheets). All references to "DCM1" in this datasheet can be taken to apply to all versions in the DCM1 range.

In most DCM1 installations, the DCM1 host unit itself will normally be located in a rack along with other audio equipment, and will not be readily accessible. Installing an ME-I module in one of the DCM1's zones provides the user with the ability to connect microphones to the audio system. The DCM1 can then be configured (using the Routing Menu) to send the microphone signal to loudspeakers in the same zone, or any other zone(s).

ME-I modules connect to the DCM1 host unit with screened Cat 5 cable. Multiple modules may be "daisy-chained" together using the "Link" connector on the rear PCB. The DCM1 supports up to four independent "chains" of ME-I modules (see "Connections"), and mics connected in any one chain may be routed to the zone in which the modules are installed - or to other zones - as required.

Each ME-I module allows either one or two mics to be connected, depending on the version (see page 2). Standard female 3-pin XLR connectors are provided on the module's faceplate; 12 V phantom power may be enabled for either input by a jumper on the rear PCB. Each input has a gain control with a very wide range, making the ME-I suitable for any type of microphone. There are also preset-type controls for HF and LF EQ adjustment. All controls are accessible from the faceplate. The two-channel versions of the ME-I combine the two inputs together and feed a mono sum to the DCM1 host unit; therefore they act as a 2-into-1 mic mixer.

Note that ME-I modules are intended for the connection of low-level audio sources only (i.e., microphones); the Cloud LE-I and BE-I Series of remote input modules are also available when in-zone connection of line level audio sources is required. Most radio mic receivers have a line level output, or an output which is selectable to line level; if radio mic receivers with line outputs are to be used with the audio system, LE-I or BE-I modules may be used to take advantage of the higher level signals, provided that the different routing options line inputs have in the DCM1 suit the operational requirements of the installation. Please see separate datasheets.

## Versions

Six versions of the ME-I are available:

- ME-IW – two mic inputs, to fit UK back boxes, white finish
- ME-IB – two mic inputs, to fit UK back boxes, black finish
- ME-IAW - two mic inputs, to fit US back boxes, white finish
- ME-IAB – two mic inputs, to fit US back boxes, black finish
- ME-IMW – one mic input, 100 x 50 mm Euro-module, white finish
- ME-IMB – one mic input, 100 x 50 mm Euro-module, black finish

The ME-IBW and ME-IBB mount into a standard dual-gang UK-style electrical back box; the ME-IAW and ME-IAB mount into a standard dual-gang US-style box. The ME-IMW and ME-IMB are single-input “Media” versions: 100 mm x 50 mm Euro-modules, which can be fitted into either UK or other European back boxes with the appropriate mounting frame.

## Connections

An ME-I module is exceptionally simple to install, as it connects to any one of the DCM1’s four Microphone Inputs with a single screened Cat 5 cable using standard shielded RJ45 connectors at each end (see fig.1). The Cat 5 cable carries DC power as well as balanced audio. Note that any or all of the DCM1 Microphone Inputs may be used.

A second “Link” connector is provided on the ME-I to permit multiple modules to be “daisy-chained” together, to provide input points at different locations in the same zone (see fig.2). Signals applied to modules wired in this way will be summed together to the DCM1 Microphone Input to which the “last” ME-I in the chain is connected. An internal gating circuit on each module automatically disables the audio circuitry on any chained modules which are not in use, to minimise noise contribution. Chained modules are treated as a single mic input at the DCM1.

Note that ME-I input modules may NOT be intermixed with LE-I or BE-I stereo line input modules in such a chaining arrangement.

ME-I’s are powered from the DCM1 to which they are connected, and each takes 43 mA at +12 V and -12 V with phantom power off. In the vast majority of installations, the DCM1 will have ample spare power capacity for several ME-I’s. Note that the DCM1 is capable of powering other active accessories, such as other types of remote input modules, or paging microphones. If these accessories form part of the system, the current available from the DCM1’s ports may be reduced. Full details are provided in the DCM1’s documentation. Also, if capacitor mics are likely to be used with the system, installers are advised to read the mic manufacturers’ data to check the DC current required.

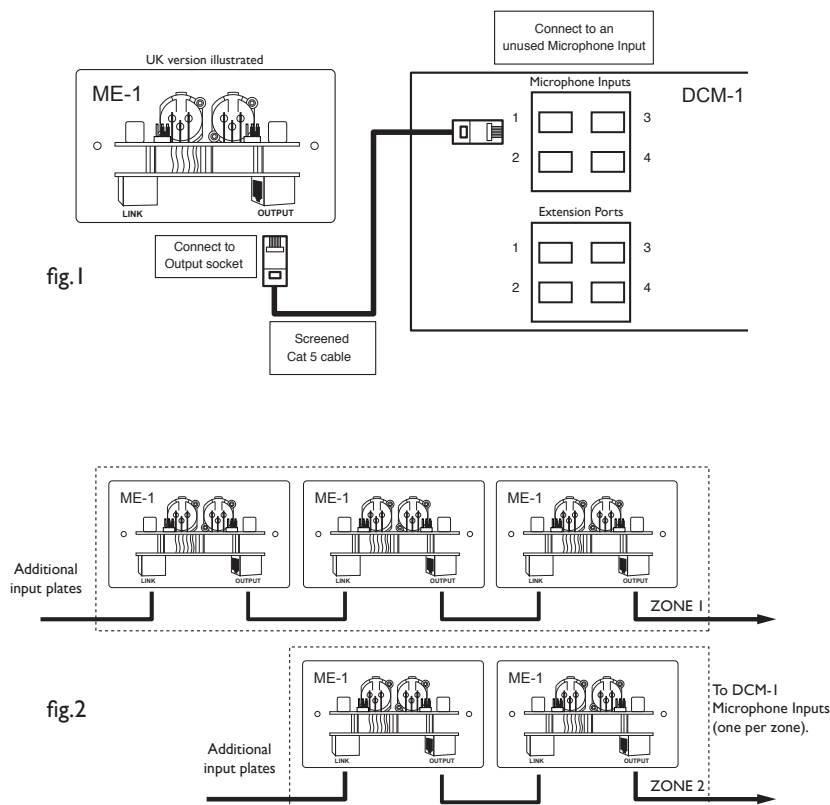

## System Example Example 1

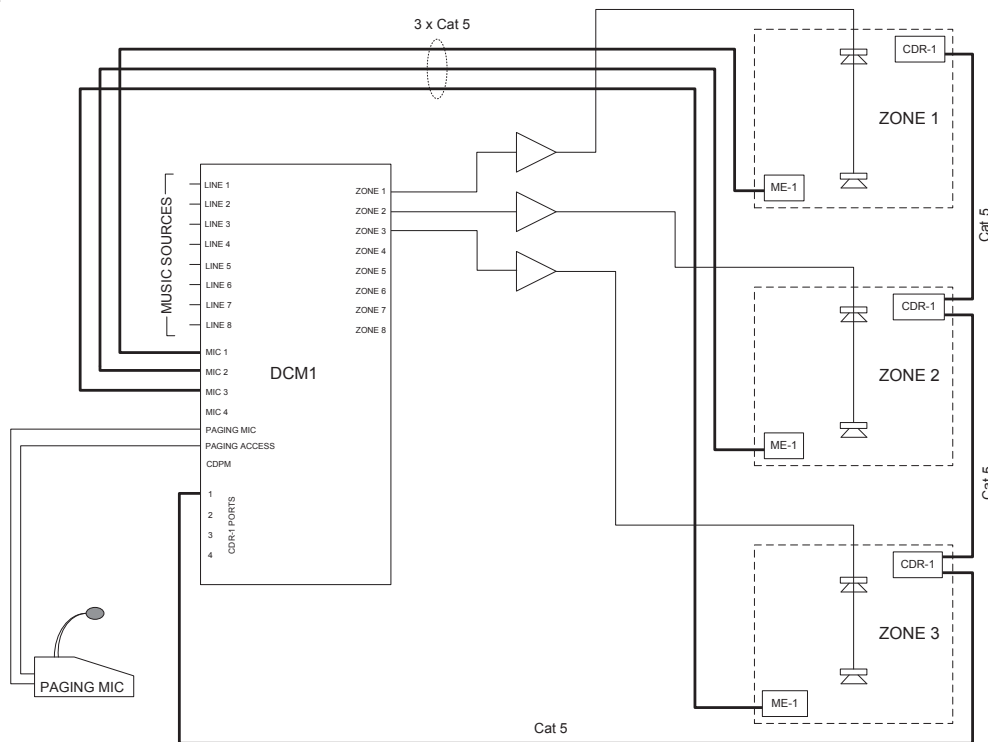

In the system shown, a DCM1 is used to route a variety of music sources to three zones. Each zone has a CDR-1 remote control plate installed, to allow the users in each area to select the music source and control the volume locally.

Each zone also has an ME-1 remote mic input module installed. Each module is wired back to a Microphone Input on the DCM1 host unit with Cat 5 cable. Although the mic inputs used in the example have been chosen to match the zones numerically, it should be noted that this is unnecessary for the correct operation of the system; the Microphone Inputs used need have no numerical relationship to the zone outputs.

Depending on the type of ME-1 module installed, either one or two microphones connected to the ME-1 in Zone 1 will now be available to any zone in the system as Mic Input 1; though in all likelihood it would normally be routed only to Zone 1, where it is fitted. The routing is made in the normal way using the DCM1's front panel display and controls to enable the mic inputs through the Routing Menu in

Installer Mode. In the same manner, mics plugged into the ME-1s in Zones 2 and 3 are selectable throughout the system as Mic Input 2 and Mic Input 3 respectively. Any mic-over-music priorities required would be set up using the DCM1's Installer Mode, in the Priorities Menu. Hold and release times, and attenuation level are all definable on a per-zone basis.

Note that a paging mic can also form part of the system, as the DCM1 has a dedicated paging mic input. This would be able to page to any or all of the DCM1's eight zones; the paging mic's priorities are separately definable in the Priorities Menu, as described above.

For clarity, the system's various music sources, and Zones 4 to 8 are not shown.

## Example 2

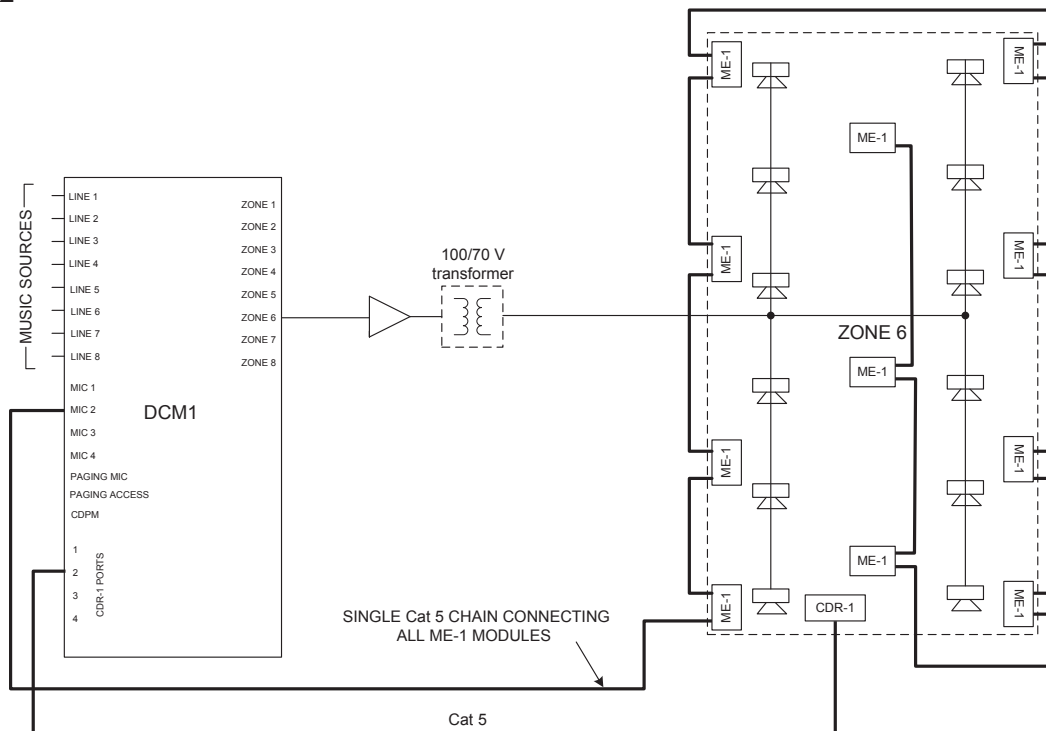

This example shows what might be a large hall or multi-purpose area forming one of the DCM1's zones (Zone 6 in this case). A single CDR-1 is fitted at one end to select and control the music routed to the area.

In such an area, a common requirement is to have the ability to connect one or more microphones anywhere in the room, to suit the type of event being held. The diagram shows a total of 8 ME-1 modules connected as two chains; typically, these might be installed in dado trunking down each side of the hall.

The ME-1s on each side of the room are connected together in "daisy-chain" arrangements using screened Cat 5, with two similar cables running back to the DCM1 host unit. Depending on the ME-1 module type, either one or two microphones may be plugged into any of the

modules, and each may have its level adjusted individually on the module faceplate. Signal from all microphones plugged in at either side of the hall will be summed to a single mono feed and will be selectable in the DCM1's menu system as Mic Input 2 or Mic Input 3.

As with Example 1, any mic-over-music priorities deemed desirable can be set up in the Priorities Menu of the DCM1's Installer Mode as required.

For clarity, the system's various music sources, and feeds to other zones are not shown.

## Architect's and Engineer's Specification

An optional remote input panel shall be available for the Cloud DCM1 range of Digitally Control Zone Mixers, and the module shall be compatible with all versions in the range. The panel shall be provided with IN and OUT RJ45 connectors to permit connection to the DCM1 host unit and other similar input modules via screened Category 5 data cable. Circuitry shall be included such that interconnected modules which do not have microphones connected do not contribute any perceptible noise to the output signal.

Versions of the module allowing the connection of one or two microphones shall be available; the connector(s) shall be 3-pin female XLR type. Each microphone input shall be provided with the following adjustments accessible from the front of the module: i) a gain control with a range of sufficient magnitude to allow microphones of any type to be used effectively; ii) controls of the preset type adjusting HF and LF shelving filters.

Versions of the module with two microphone inputs shall combine the two inputs to a single mono sum output.

The remote input module shall be available in versions suitable for fitment in standard UK or US dual-gang back boxes. There shall also be a version with a front panel measuring 100 mm x 50 mm suitable for mounting in standard Euro-style modular mounting frames. The modules shall be available in a choice of finishes.

The remote input modules shall be the Cloud ME-1W (UK version, white finish) and Cloud ME-1B (UK version, black finish), the Cloud ME-1AW (US version, white finish) and Cloud ME-1AB (US version, black finish), the Cloud ME-1MW (Euro-module, white finish) and Cloud ME-1MB (Euro-module, black finish).

### Cloud Electronics Limited

140 Staniforth Road, Sheffield, S9 3HF. England.  
Telephone: +44 (0)114 244 7051 Fax: +44 (0)114 242 5462  
Web: www.cloud.co.uk E-mail: info@cloud.co.uk

### Cloud Electronics USA

2065 Sidewinder Drive, Suite 200, Park City,  
Utah 84060. United States of America.  
Toll Free: 0855 810 0161  
Web: www.cloudusa.pro E-mail: sales@cloudusa.pro