

LE-1 Series

Line Input Modules

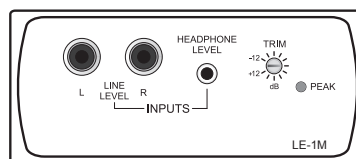
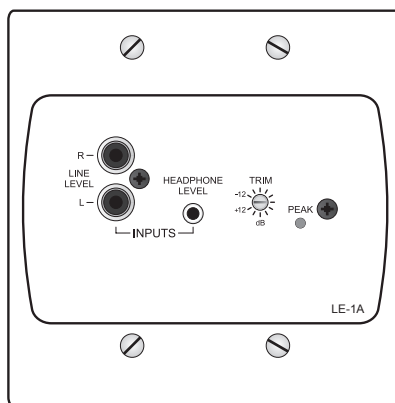
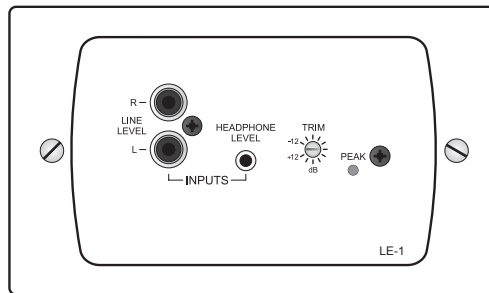

Installation Guide

Introduction

The LE-I is a remote line input module for use with the Cloud DCM1 range of Digitally Controlled Mixers. It cannot be used with any other Cloud product.

NOTE 1: All references to “DCM1” in this Installation Guide can be taken to apply to all models in the DCM1 range.

NOTE 2: Unless specifically stated otherwise, all references to “LE-I” in this Installation Guide can be taken to apply to all LE-I mechanical and cosmetic variants.

This document provides information on how to connect LE-I's into an audio system based on a DCM1. Further information on configuring the DCM1 itself for use with LE-I's can be found in the DCM1 Installation and User Guide.

The LE-I allows a stereo unbalanced line-level audio source, such as a portable music centre, laptop, radio mic receiver or similar to be connected into a DCM1-based audio system.

Two types of input connector are provided: dual phono sockets for line level signals (with a nominal level of 0 dBu), and a 3.5 mm stereo jack socket for higher level signals (approx. +8 dBu nominal), such as are found at the headphone output sockets of portable audio devices. Gain trim adjustment (± 12 dB) is available on the faceplate, and a red “Peak” LED illuminates when an input signal exceeds nominal level. The gain should be adjusted so that the LED illuminates briefly only on the loudest sections of audio programme.

Mounting - mechanical

LE-I (UK version)

The Cloud LE-I fits a standard UK-style dual-gang electrical back box. The box used should have a depth of at least 35 mm. 2 x M3.5 screws are supplied with the module.

LE-IA (US version)

The Cloud LE-IA fits a standard US dual-gang electrical ‘J’ box in vertical orientation. The box used should have a depth of at least 1¼”. 4 x 6-32 screws are required to secure the module.

LE-IM (Media version)

The Cloud LE-IM is a 100 x 50 mm “Euro-module”, and is designed to clip into a mounting frame with this size cut-out (not supplied). Suitable mounting frames are available in most European and other territories, to fit local electrical back box dimensions. Ensure that the back box has a depth of at least 35 mm. The module is secured in place by the six plastic clips (three top, three bottom).

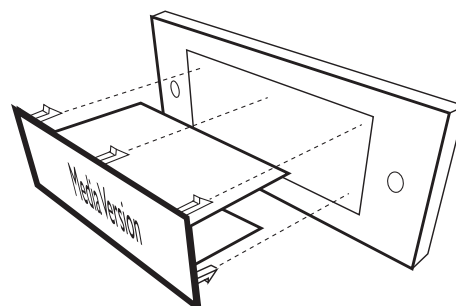

Mounting frame to suit UK-style double-gang back box illustrated.

Wiring

The LE-1's OUTPUT connector should be connected to one of the DCM1's EXTENSION PORTs (Line inputs 1 to 4) with screened Cat 5 cable and shielded RJ45 plugs. Do not connect any other equipment to the phono sockets of the same-numbered Line Input on the DCM1.

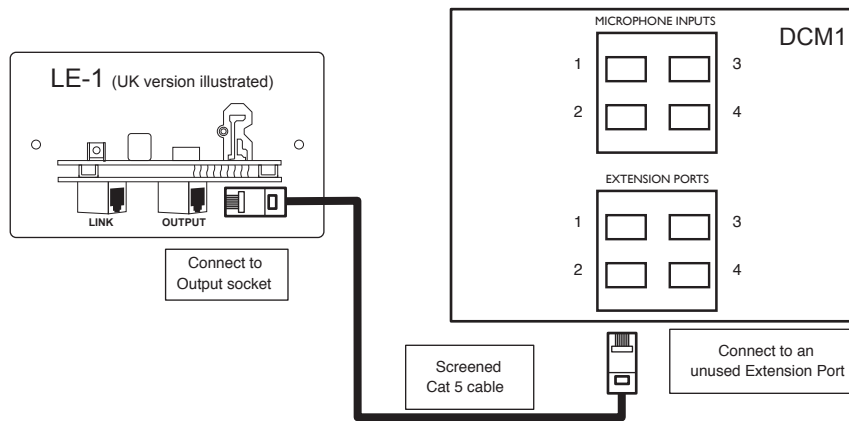

Note that all LE-1s have two RJ45 connectors, OUTPUT and LINK. These are both mounted on the lower PCB, with the OUTPUT connector on the right (looking at the module rear), and the LINK connector on the left.

IMPORTANT: Because the cables carry low-level audio, *only* screened Cat 5 should be used, the foil screen of the cable being bonded to the metal screening can of the plugs. If an LE-1 is being mounted in close proximity to the DCM1, it may be possible to use ready-made screened Cat 5 “patch” cables of an appropriate length. Otherwise, shielded RJ45 plugs should be crimped onto the installed screened Cat 5 cable using the pinout shown below.

PIN	USE	CAT-5 CORE
1	Left (cold)	White + Orange
2	Left (hot)	Orange
3	Sense	White + Green
4	DC +ve	Blue
5	0v	White + Blue
6	DC -ve	Green
7	Right (hot)	White + Brown
8	Right (cold)	Brown
SCN	Screen	Connector Shell

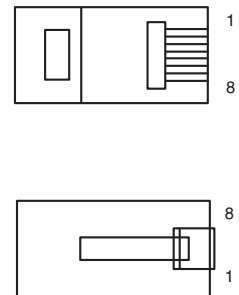

Connecting Multiple LE-I's

Multiple LE-I's may be “daisy-chained” together to provide input points at different locations in the same zone. Signals applied to modules wired in this way will be summed together and fed to the DCM1 Line Input to which the “first” LE-I in the chain (that whose OUTPUT socket is connected directly to the DCM1). An internal gating circuit on each module automatically “disconnects” any chained modules which are not in use, to minimise noise contribution. Chained modules will be treated as a single line input at the DCM1.

Multiple LE-I's in the same zone may be daisy-chained by connecting the LINK RJ45 socket on the first LE-I to the OUTPUT socket on the second LE-I, and so on, as shown below.

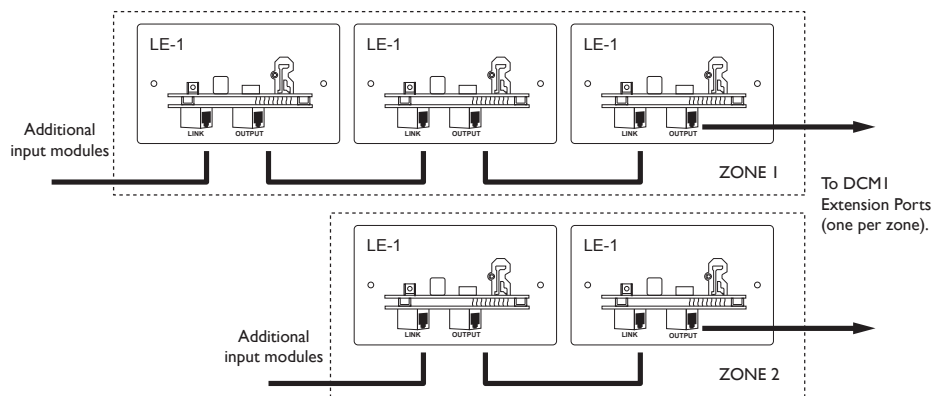

Interconnecting LE-I and BE-I remote input modules

The Cloud BE-I is an alternative range of optional remote line input modules, and provide a balanced stereo line input on XLR connectors. LE-I modules may be intermixed with BE-I's in a daisy-chain wiring arrangement in the manner described for LE-I's alone, using the BE-I's OUTPUT and LINK connectors. All the modules on a chain will be treated as a single line input at the DCM1.

Note that is not possible to intermix LE-I's with Cloud ME-I remote microphone input modules in this manner.

DC Power

The LE-I is powered from the DCM1's EXTENSION PORTs via the Cat 5 connection. The LE-I consumes 22 mA of current from the DCM1 power supply.

If there is any doubt regarding the DCM1's spare DC power capacity (as might be the case in a very large system with many CDR-I remote controls, level restoration relays, etc.), please refer to the DCM1 Installation and User Guide (*Appendix; PSU capacity*) where full details of the DCM1's PSU ratings can be found.

Should you have any questions concerning the installation and connection of the LE-I, please visit www.cloud.co.uk/resources, where you will find additional technical information.

Cloud Electronics Limited

140 Staniforth Road, Sheffield, S9 3HF. England.
 Telephone: +44 (0)114 244 7051 Fax: +44 (0)114 242 5462
 Web: www.cloud.co.uk E-mail: info@cloud.co.uk

Cloud Electronics USA

2065 Sidwinder Drive, Suite 200, Park City, Utah 84060. United States of America.
 Toll Free: 0855 810 0161
 Web: www.cloudusa.pro E-mail: sales@cloudusa.pro