



# LE-I

## Remote Line Input Plate

### Installation Guide

---

#### Introduction

The LE-I is a remote line input plate for use with the Cloud DCM-I Digitally Controlled Mixer, and cannot be used with any other Cloud product. This document provides information on how to connect LE-I's into a DCM-I-based audio system. Further information on configuring the DCM-I itself for use with LE-I's can be found in the DCM-I Installation and User Guide.

The LE-I allows a stereo unbalanced line-level audio source, such as a portable music centre, laptop, radio mic receiver or similar to be connected into a DCM-I-based audio system.

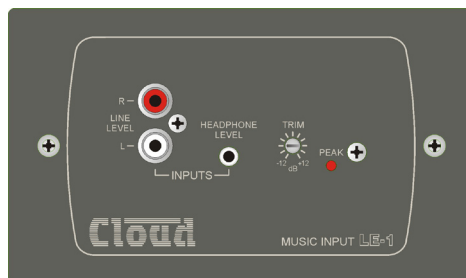

## Introduction - continued

Two types of input connector are provided: dual phono sockets for line level signals with a nominal level of 0dBu, and a 3.5mm stereo jack socket for higher level signals (approx. +8dB nominal), such as are found at the headphone output sockets of portable audio devices. Gain trim adjustment ( $\pm 12\text{dB}$ ) is available on the faceplate, and a red "Peak" LED illuminates when an input signal exceeds nominal level. The gain should be adjusted so that the LED illuminates briefly only on the loudest sections of audio programme.

## Mounting - mechanical

The Cloud LE-I fits a standard dual-gang electrical back box. The back box used should have a depth of at least 35mm (1.25"). Note that the LE-I is made in various faceplate sizes to suit standard electrical plate sizes in use in the UK, USA and Australia; ensure you have the correct version for your territory.

## Wiring

The LE-I's OUTPUT connector should be connected to one of the DCM-1's EXTENSION PORTs (Line inputs 1 to 4) with screened CAT-5 cable and shielded RJ45 plugs. Do not connect any other equipment to the phono sockets of the same-numbered Line Input on the DCM-1.

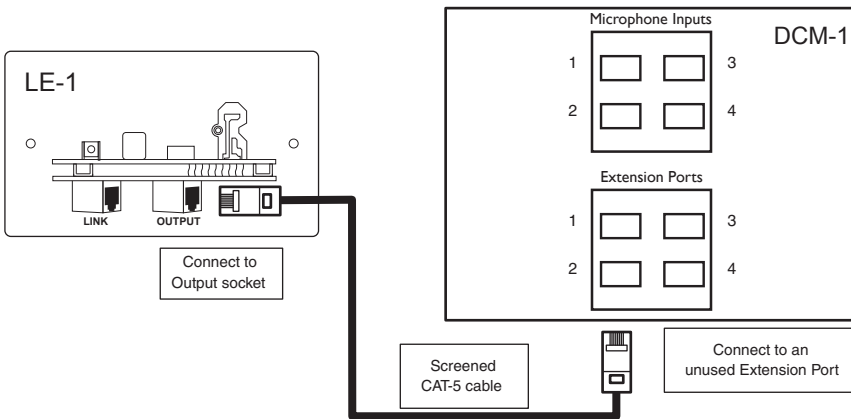

Note that because the cables carry low-level audio, only screened CAT-5 should be used, the foil screen of the cable being bonded to the metal screening can of the plugs. If an LE-I is being mounted in close proximity to the DCM-I, it may be possible to use ready-made screened CAT-5 “patch” cables of an appropriate length. Otherwise, shielded RJ45 plugs should be crimped onto the installed screened CAT-5 cable using the pinout shown below.

PIN	USE	CAT-5 CORE
1	Left (cold)	White + Orange
2	Left (hot)	Orange
3	Sense	White + Green
4	DC +ve	Blue
5	0v	White + Blue
6	DC -ve	Green
7	Right (hot)	White + Brown
8	Right (cold)	Brown

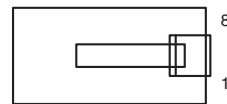
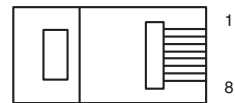

## Connecting Multiple LE-I s

Multiple LE-I s may be “daisy-chained” together to provide input points at different locations in the same zone. Signals applied to plates wired in this way will be summed together to the DCM-I Line Input to which the “last” LE-I in the chain is connected. An internal gating circuit on each plate automatically “disconnects” any chained plates which are not in use, to minimise noise contribution. Chained plates will be treated as a single line input at the DCM-I.

Multiple LE-I s in the same zone may be daisy-chained by connecting the LINK RJ45 socket on the first LE-I (that whose OUTPUT socket is connected directly to the DCM-I) to the OUTPUT socket on the second LE-I, and so on, as shown on page 4.

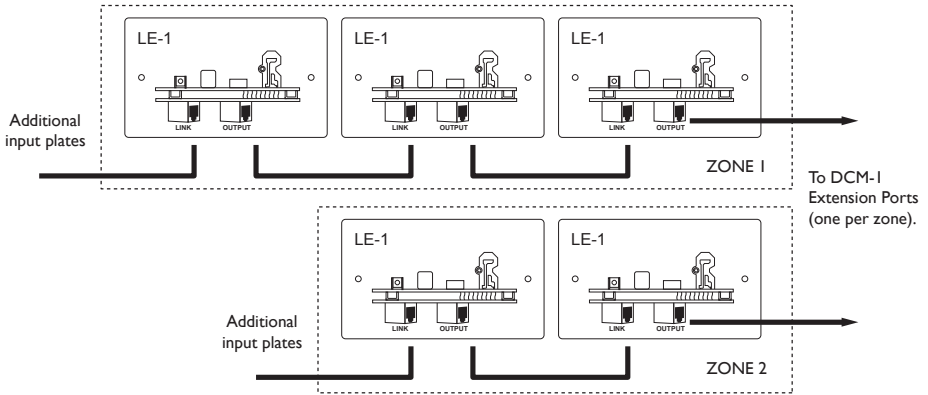

## Interconnecting LE-I and BE-I remote input plates

The Cloud BE-I is an alternative optional remote line input plate, providing a balanced stereo line input on XLR connectors. LE-I plates may be intermixed with BE-Is in a daisy-chain wiring arrangement in the manner described for LE-Is alone, using the BE-I's OUTPUT and LINK connectors. All the plates on a chain will be treated as a single line input at the DCM-I.

Note that it is not possible to intermix LE-Is with Cloud ME-I remote microphone input plates in this manner.

## DC Power

The LE-I is powered from the DCM-I's EXTENSION PORTS via the CAT-5 connection. The LE-I consumes 22mA of current on both the +12V and -12V rails from the DCM-I power supply.

If there is any doubt regarding the DCM-I's spare DC power capacity (as might be the case in a very large system with many CDR-I remote controls, level restoration relays, etc.), please refer to page 53 of the DCM-I Installation and User Guide where full details of the DCM-I's PSU ratings can be found.

Should you have any questions concerning the installation and connection of the LE-I, please contact our Technical Support staff (details on front cover).