

# DCM-I : Digitally Controlled Mixer



## General Description

Cloud's latest offering, the DCM-I, provides any space-conscious sound installation with a high level of flexibility, but without the need of a PC. It is ideal for contractors/installers who require flexible routing of line and mic signals. The analogue zoner, with its simple-to-use digital control interface, can be controlled remotely via multiple LCD digital controllers. Optional active input modules extend the flexibility further. The DCM-I is

Cloud's first ever microprocessor controlled multi zoner. With traditional "installer friendly" analogue I/O and signal path, but giving the contractor the flexibility and adaptability of digital control. The traditional simplicity of Cloud products, with far greater functionality.

- 8 stereo line inputs (1 balanced)
- 8 balanced line outputs (2 stereo + 6 mono)
- 4 dedicated ports for optional remote line input modules
- 4 dedicated ports for optional remote mic input modules
- Mic paging to all zones with fully programmable override logic
- Separate analogue paging mic input with contact closure zone selection
- Separate RJ45 interface for CDPM Series digital paging microphones
- Supports multiple CDR-I Remote Controls (optional) in any wiring configuration
- CDR-I provides local control of source, level, EQ and group enable
- 2 x 16 character LCD dot-matrix display (both DCM-I and CDR-I)
- 4 definable zone groups
- Any line input may have priority in any zone; operation also configurable per-zone
- Key-protected "Installer" mode (both DCM-I and CDR-I) prevents user access to configuration menus
- Inputs, zones and groups can be named RS232 interface for control by third-party control systems
- Front-panel LEDs confirm remote access
- Accepts Bose® EQ cards
- No PC required
- Multiple DCM-I's may be cascaded for larger systems
- External Music Mute input for interfacing with emergency systems
- Any input (mic or line) may be assigned as Emergency Input, overriding Music Mute
- 2U 19" rack-mounting unit

## System Example - Hotel/Large Restaurant (DCMI)

- The large area has two CDR-1 remote controls in the same zone; typically, these might be adjacent to doors at opposite ends of the room.
- Two of the areas are separated by a folding partition which may be removed to create one large space. By assigning these two zones to a Group within the DCM-1, the two zones can be treated as one for audio purposes when the partition is removed and return to two separate zones when it is reinstated.
- Each half of the partitioned area also has an ME-1 mic input plate. Because these have been wired back to the DCM-1 independently, each can be made available to their respective room halves as and when required. Alternatively, it may be that they are only required when the partition is folded back; in this case they are activated for the Group instead.

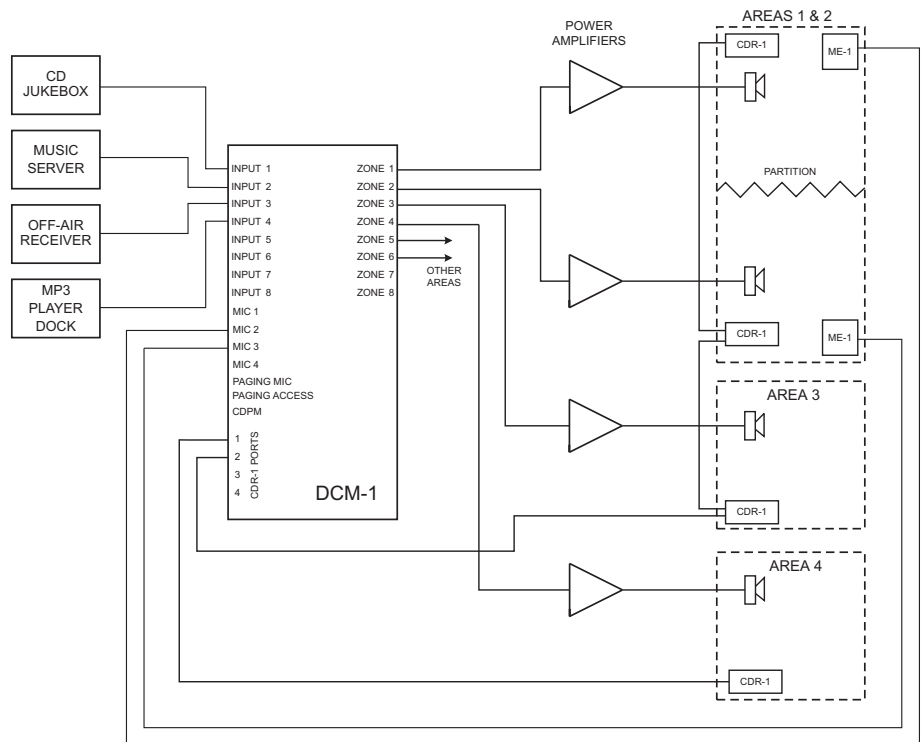

## Technical Specifications

### Line Inputs

Frequency Response	20Hz - 20kHz $\pm$ 1dB
Distortion	<0.05%, 20Hz - 20kHz
Sensitivity	195mV (-12dBu) to 3.1V (+12dBu)
Input Gain Control	24dB range
Input Impedance	47k $\Omega$
Headroom	>+10dB
Noise	-90dB A weighted (0dB gain)
Equalisation	HF: $\pm$ 14dB/10kHz MID: $\pm$ 14dB/1200Hz LF: $\pm$ 14dB/50Hz

### Paging Microphone Inputs

Frequency Response	100Hz / -3dB(filter) to 20kHz $\pm$ 0.5dB
Distortion	<0.05% 20Hz-20kHz
Gain Range	10dB - 50dB
Input Impedance	>2k $\Omega$ (balanced)
Phantom Power	+12V (PCB jumper for on/off)
Headroom	>20dB
Noise	-120dB EIN 22Hz - 22kHz (150 $\Omega$ )
Equalisation	HF: $\pm$ 10dB/5kHz LF: $\pm$ 10dB/100Hz

### Outputs

Balanced Zone Outputs	775mV (0dBu)
Minimum load impedance	600 $\Omega$
Maximum output level	+10dBu (2.6V)

### External Power Supply

External Supply Input	100V-240V AC; 47-63Hz; 1.35A
Power supply	+12V, 3A; -12V 1A

### Physical

Dimensions (w x h x d)	482.6mm x 88mm x 170mm deep (2U 19" rackmounting unit). Dimensions do not allow for rear connectors/cabling.
Weight	3.12 kg net

# Graphs

DCM-I Line Input Frequency Response Stereo Output

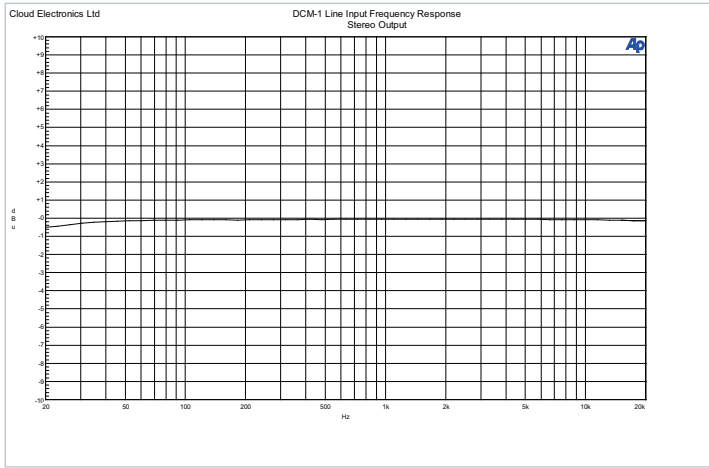

DCM-I Line Input EQ Curves

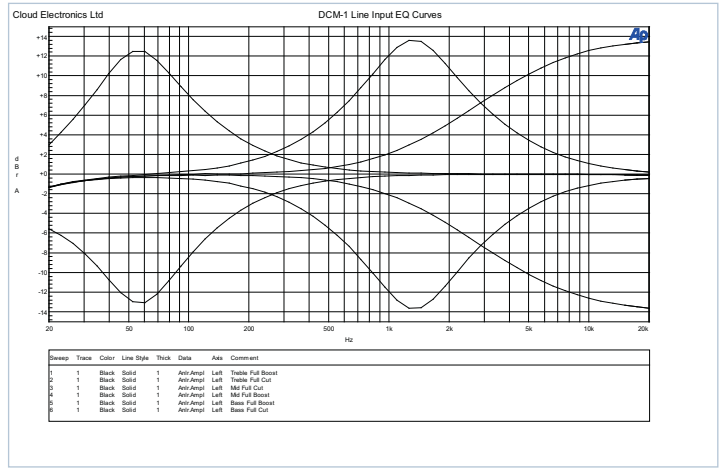

DCM-I Adjacent Line Input Crosstalk

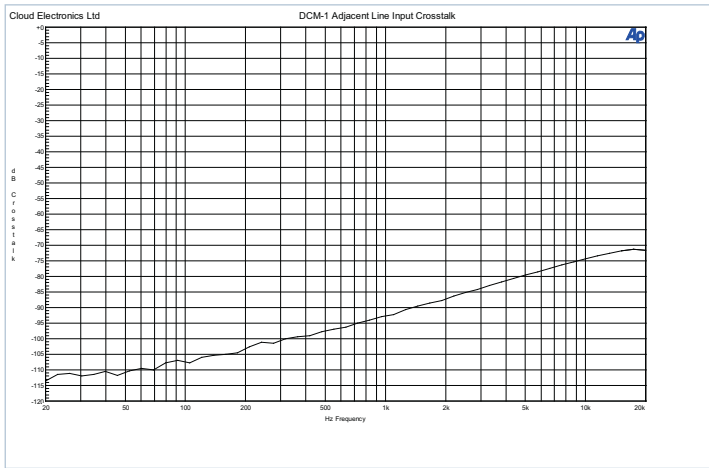

DCM-I Line Input Frequency Response Stereo Output

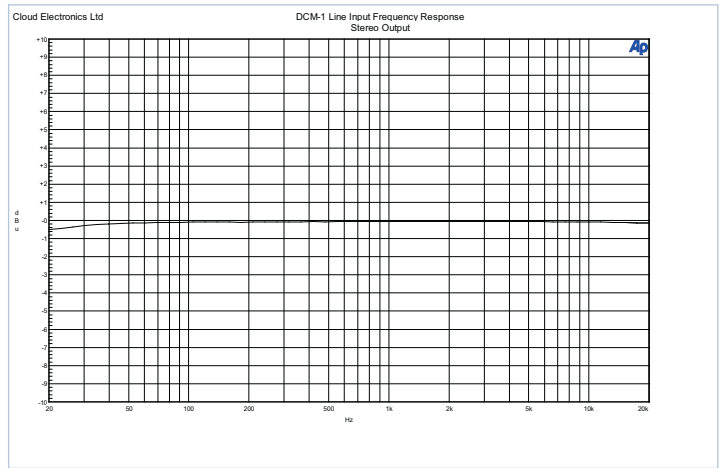

DCM-I Adjacent Line Input Crosstalk

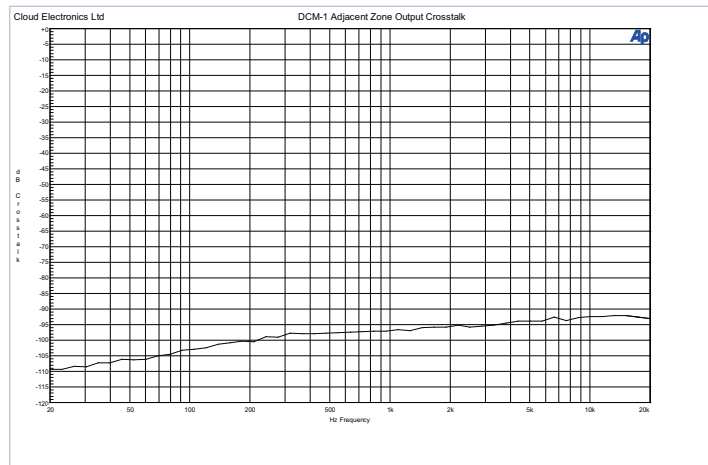

## Block Diagram

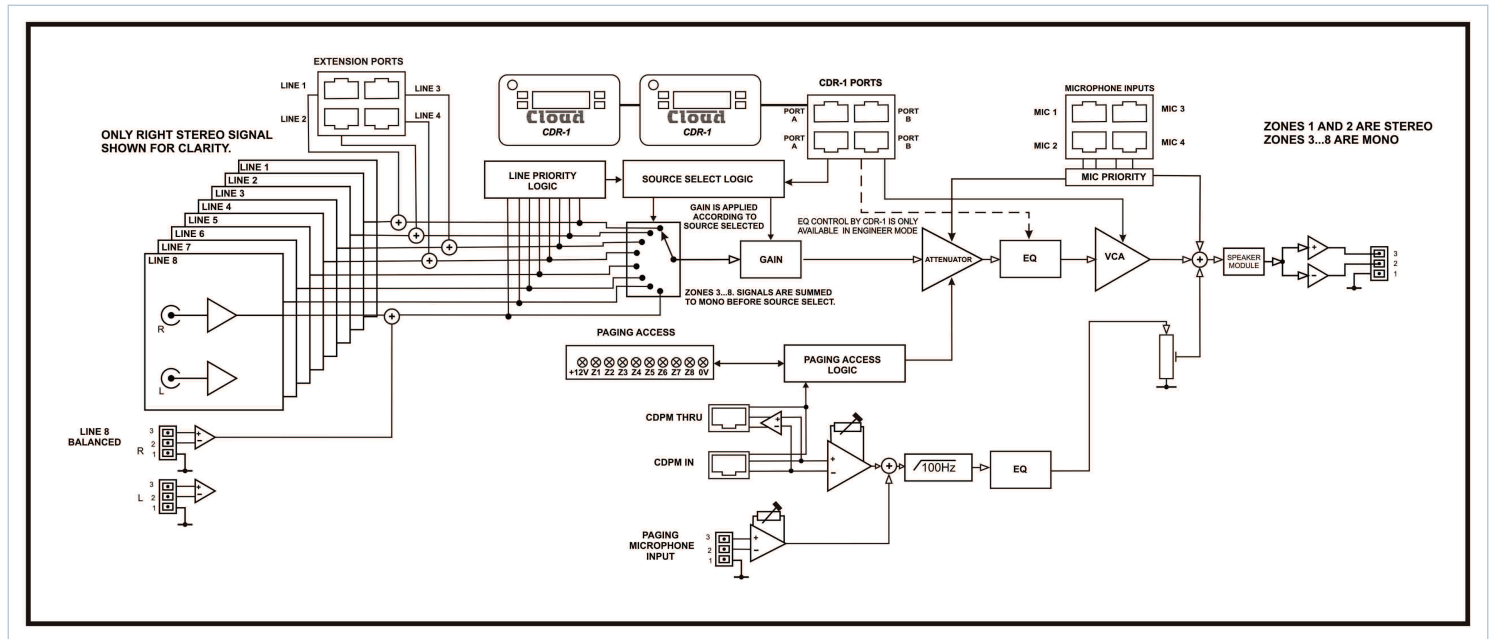

## Architect's and Engineer's Specification

All control functions will be self-contained and not require any external computers or software. The Mixer/Zoner shall be built in a steel chassis for mounting in a standard 19" rack enclosure.

The front panel shall include: power switch, backlit LCD display; rotary encoder with "press" function and software-assignable push-buttons for control functions. One of the buttons shall control the Mixer/Zoner's menu system. Five further buttons shall select submenus, and another button shall activate a set of menu options which require the entry of a password. The password shall be re-definable by the User. The front panel will have various LEDs indicating: external paging access, remote line input selection, remote mic input selection and emergency Music Mute activity.

The Mixer/Zoner shall have 8 stereo line channels, 4 microphone inputs and a paging mic input. Line inputs shall be on RCA jacks, one shall also be available as a balanced input on a Euroblock connector; four shall also have RJ45 sockets providing balanced inputs for the connection of optional balanced or unbalanced stereo external connection plates. The microphone inputs shall be balanced on RJ45 sockets for the connection of optional external connection plates. The line inputs shall each have level trim adjustment via software.

The Zone outputs shall be balanced, on Euroblock connectors. Two shall be stereo, the remainder mono. It shall be possible to adjust the following parameters for each Zone output: Level, Maximum and Minimum Levels; EQ (3-bands). It shall be possible to route any microphone or line input to any Zone output without restriction, and to adjust each Zone output level independently. It also shall be possible to make one or more line inputs unavailable to any Zone without restriction. It shall also be possible to define up to 4 Groups of Zones; enabling/disabling Groups shall be possible without entering the password.

The Mixer/Zoner shall interface directly with a Cloud CDPM network and/or any other paging microphone. The (non-CDPM) Paging Mic input shall be on a Euroblock connector; routing this to any/all Zones will be by contact closure at a separate Euroblock connector. Both Paging Mic inputs shall have rear panel gain controls; HF and LF EQ controls shall also be provided, effective on both inputs.

There shall be a rear panel paging level adjustment for each Zone. The music signal in a Zone shall reduce in volume when that Zone is being paged, and the Hold

Time, Release Time and Music Attenuation shall all be adjustable. It shall also be possible to trigger music level reduction by Zone Selection or Paging Mic signal presence. It shall be possible to assign per-Zone Priority status to any line or microphone input, such that a Priority signal above a fixed threshold overrides the current Input selection in each Zone for as long as the Priority signal remains above the threshold. In connection with this, the following parameters shall be adjustable: Hold Time, Release Time; Music Attenuation (Mic Priority only).

There shall be a Music Mute Input, a control signal at which mutes the Music in all Zones. Muting control shall be configurable on either external contact closure (NO) or short-circuit removal (NC). It shall also be possible to assign any one line or microphone Input to remain unmuted during Music Mute operation for Emergency system interface. It shall be possible to assign alphanumeric names to all Inputs, Zones and Groups; these will still apply after any hardware reset operation.

It shall be possible to save all current settings and reload these settings when power is applied. Alternative power-up options shall be to load the original factory settings or those in force at power-down, even if they were not specifically saved.

The Mixer/Zoner shall include an RS232 serial port permitting remote control of all unit functions and settings. An optional remote control panel shall be available for the Mixer/Zoner. The panel shall be provided with IN and OUT sockets to permit series interconnection of up to 100 panels in any wiring configuration. It shall be possible to configure a panel to provide the following control functions for its assigned Zone: for immediate access - Line Input Select and Music Level; with password entry - Zone EQ (3 bands).

It shall be possible to retro-fit certain Type II Bose equaliser cards to any or all Zone outputs. Compatible cards shall include Bose Product Codes 035467/70-3/5/6 and 038533 as a minimum. The Mixer/Zoner shall be the Cloud DCM-1; the remote control panel the Cloud CDR-1; the remote input plates the Cloud LE-1 (unbalanced line), Cloud BE-1 (balanced line) and Cloud ME-1 (microphone).