

Using an RSL-6 (or RSL-6A*) for source selection in multiple zones

Preamble:

This Technical Note describes the modifications which need to be made to an RSL-6 remote control plate to enable music source selection to be applicable to more than one zone at a time. The system wiring details associated with this modification are included.

The RSL-6 is a remote control plate accessory for use with a number of different Cloud products that cater for six different music sources. It allows remote selection of the music source and control of the volume in a particular zone to be made from the plate instead of the front panel of the main zoner or mixer, the plate usually being installed somewhere in the zone itself. Normally, every zone requiring remote control in this way will need an RSL-6 to be connected to the main unit's remote control port for that zone. However, although this provides maximum operational flexibility, it is often more important to ensure that the same source is fed to several zones, particularly if they are adjacent and not physically separated by walls or partitions, as is typically the case in restaurants and bars.

The procedure can be applied to any or all of the zones which the master unit supports. The maximum number depends on the unit, see Table 1.

Applicable products:

The RSL-6 is compatible with several current products, as listed in Table 1 below. In most circumstances, this modification will be applied to a single unit supporting at least two zones. However, it is also possible to apply it to zones on two or more separate units, thus single-zone products are also compatible (see Note 3 in Limitations on page 2).

CATEGORY	PRODUCT	NO OF ZONES
Venue Mixers	Z4II	4
	Z8II	8
Zone Mixers	CX261	1
	CX263	3
Audio System Contoller	CX462	1
Integrated Mixer Amplifiers	46/50	4
	36/50	2
General Purpose Mixer Amplifiers	MPA60	1
	MPA120	1
	MPA240	1

Table 1

Required Skill Level: Medium.

(Not recommended for those inexperienced in removing/replacing soldered PCB components.)

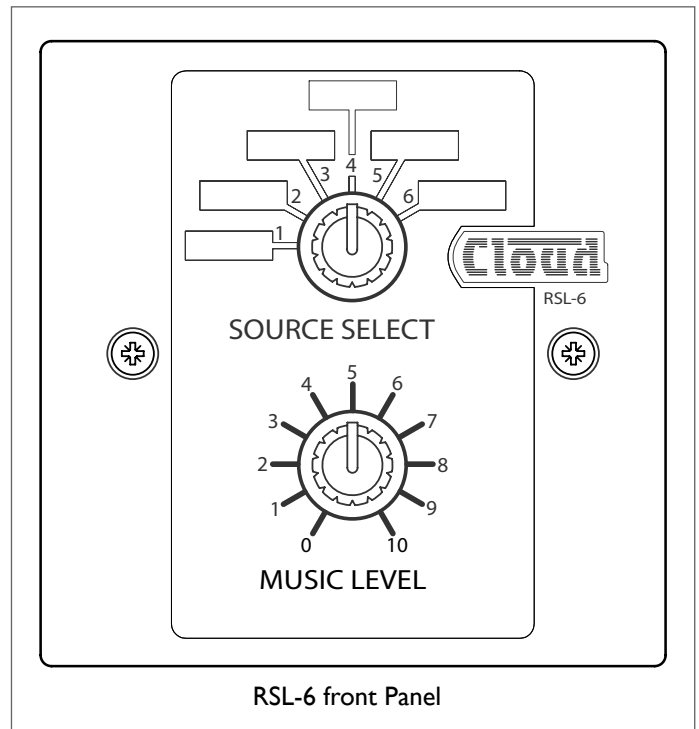

The modification is also applicable to legacy products fitted with the same remote control interface – i.e. compatible with the RSL-6

*The RSL-6A is a mechanically different variant which fits a standard USA-size electrical box. All details of this Technical Note are also applicable to this version

Limitations:

1. This modification only makes the RSL-6's source selection function applicable across multiple zones. The panel's level control function will apply only to the zone to which the panel is connected (but see note on page 3.)
2. The Local/Remote switches on the master unit must be set to Remote, and the internal override switches set to SW, on all Zones that are to have remote source selection. This will disable both the front panel source and level controls for those zones. Consequently this modification also requires that either RL-1 remote level control plates are fitted in the zones other than the one to which the RSL-6 is wired directly, or that some other external DC voltage control method is employed in those zones.
3. If the zones being paralleled are on physically separate units, all the units must be of the same mains voltage type, and be sufficiently close together that no earthing problems arise from interconnecting the 0V reference.

Parts required:

Five ¼-watt (min.) 1% resistors (see Table 2 below for values), two-core screened cable

	Number of zones to be controlled							
	1	2	3	4	5	6	7	8
R1	5k6	2k7	1k8	1k3	1k2	1k	910	750
R2	3k9	2k	1k3	1k	750	680	560	510
R3	2k7	1k3	1k	750	620	510	430	360
R4	2k2	1k1	750	620	470	390	330	300
R5	1k8	910	560	390	330	270	240	200

Table 2: required resistor values depend on the number of zones in which common music source selection is required. (Values are in Ohms).

Tools required:

Soldering iron (max. 25W), de-soldering tool, small wire-cutters, small pliers, 11 mm spanner (preferably box type), small screwdriver, small vice (optional).

Procedure - modification:

1. If the RSL-6 plate is already installed, first power the system off, then disconnect the plate and remove it from its back box. If it is a new one, unpack it.
2. Remove the two knobs by levering them gently off their shafts with a small screwdriver. Use a piece of scrap paper to protect the faceplate while doing this. Undo the two nuts securing the PCB to the plate with an 11 mm spanner. A box-type spanner is recommended as it is less likely to mark the faceplate. Remove the PCB.
3. Remove the five resistors R1 to R5. Use de-soldering braid or a de-soldering tool on the track side of the PCB to remove all the solder from the pad.

Apply only as much heat as necessary to melt the solder, to avoid lifting the track. When the holes at both ends of a resistor are clear, turn the board over and remove it with a small pair of pliers. Carefully clamping the PCB in a small bench vice will make this step and the next much easier.

4. Clear any remaining solder in the holes with the de-soldering tool. Referring to Table 2, fit and solder the new resistors in the correct positions. Take care not to create solder bridges between pads.
5. Refit the PCB to the plate by reversing Step 2. The modified plate is now ready for connection.

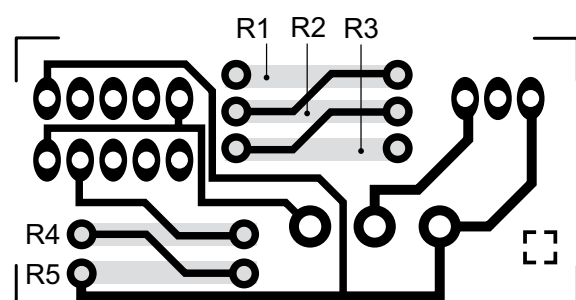
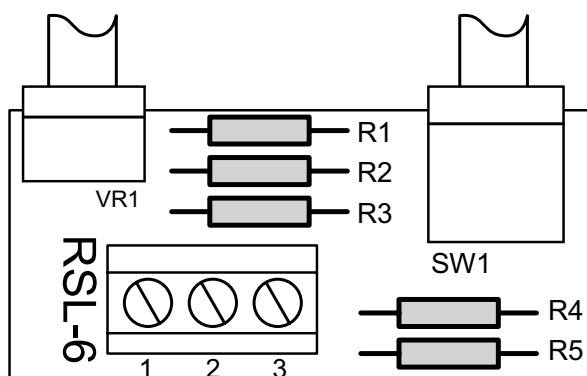

System wiring and setup:

The remote control ports on the rear panels of Cloud host units always use the same connectors (mating connectors are supplied with the units) and have the same pinout. Their rear panel positions will vary with model. The wiring diagram below is based on a Z4II Venue Mixer; the same procedure should be followed for all other models.

The RSL-6 should be connected with screened two-core cable to one zone in the normal way, but Pin3 should be paralleled to as many additional zones as need to have their music source selected simultaneously (in the example, all four). Set the Local/Remote switches on all paralleled zones to 'Remote'.

Note that the level control on the RSL-6 will only control the volume in Zone 4, and separate arrangements will need to be made for volume control in the other zones.

NOTE: Paralleling the remote level control function of the RSL-6 to more than one zone is also technically possible, but note that the law of the level control will be compromised. Furthermore, the law gets progressively worse the greater the number of zones that are connected, making accurate level control hard to achieve.

RSL-6 (rear view)

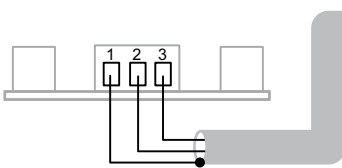

PIN	FUNCTION
1	Screen
2	Level
3	Source

Table 3 gives the pinout of the remote control ports.

