



44/50 4 Zone Integrated
Mixer Amplifier
Installation & Operation Manual

Cloud Electronics Limited

140 Staniforth Road, Sheffield, S9 3HF England

Tel + 44 (0) 114 244 7051

Fax + 44 (0) 114 242 5462

E-mail info@cloud.co.uk

Web site <http://www.cloud.co.uk>

44/50 Integrated Four Zone Mixer Amplifier

Installation and Operation manual

Contents

Section		Page
1	Safety notes.....	2
2	General description.....	2
3	Schematic diagram	2
4	Installation	3
5	Music inputs.....	3
6	Sensitivity & gain control.....	3
7	Music control – local or remote	3
8	Music equalisation	3
9	Line 4 priority	4
10	Microphone inputs	4
11	Paging microphone.....	4
12	Connecting Multiple CPM-4s to the 44/50	4
13	Microphone gain control.....	5
14	Microphone equalisation	5
15	High pass filter	6
16	Microphone level controls	6
17	Microphone priority	6
18	Auxiliary outputs	6
19	Output details.....	6
20	100V or 70V line operation.....	6
21	Remote music mute – fire alarm interface.....	7
22	Fitting and configuring the REM-4 remote control module.....	7
23	Special notes regarding the use of the REM-4	7
24	Music signal processing PCB.....	8
25	Installing RSL-1 or RL-1 remote controls	8
26	Controlling two or more zones with one RL-1.....	8
27	Controlling two or more zones with one RSL-1	9
28	Front panel music level control defeat.....	9
29	Controlling the music functions using external DC control.....	10
30	EMC considerations.....	10
31	Technical specifications	11
32	General specifications.....	11

1 Safety Notes

The Cloud 44/50 contains several PCB mounted jumpers which can be set to provide the desired configuration for a specific application; these adjustments should be performed by a technically qualified person who fully understands the hazards associated with mains operated equipment. Do not remove the top panel unless you are qualified to do so.

Remove the power cable from the unit before removing the top panel and do not make any adjustments with the unit switched on.

The Cloud 44/50 is supplied with a power cable fitted with a moulded plug; if the plug is cut off the lead for any reason, remember that the discarded plug is a potential hazard and should be disposed of in a responsible manner.

2 General

The Cloud 44/50 is a versatile, multi-source four zone mono mixer with four 50 watt power amplifiers. The unit has applications where two microphone and four line level music signals are required to feed four separate areas in any combination. Optional accessories extend the flexibility of the unit: A dedicated four zone paging mic with pre-announcement chime is available, a plug-in remote control PCB provides remote control of music level and source and for line distribution systems, a four channel 100V/70V line transformer module is also available.

The front panel controls are reduced to a minimum to reduce confusion; if preferred, the unit can be positioned in a protected area with just the remote music level and source controls positioned in the most appropriate location. All pre-set controls are either on the rear panel or protected by covers.

A remote music mute facility is provided which may be used to satisfy the requirements of the Local Fire Officer.

3 Schematic Diagram

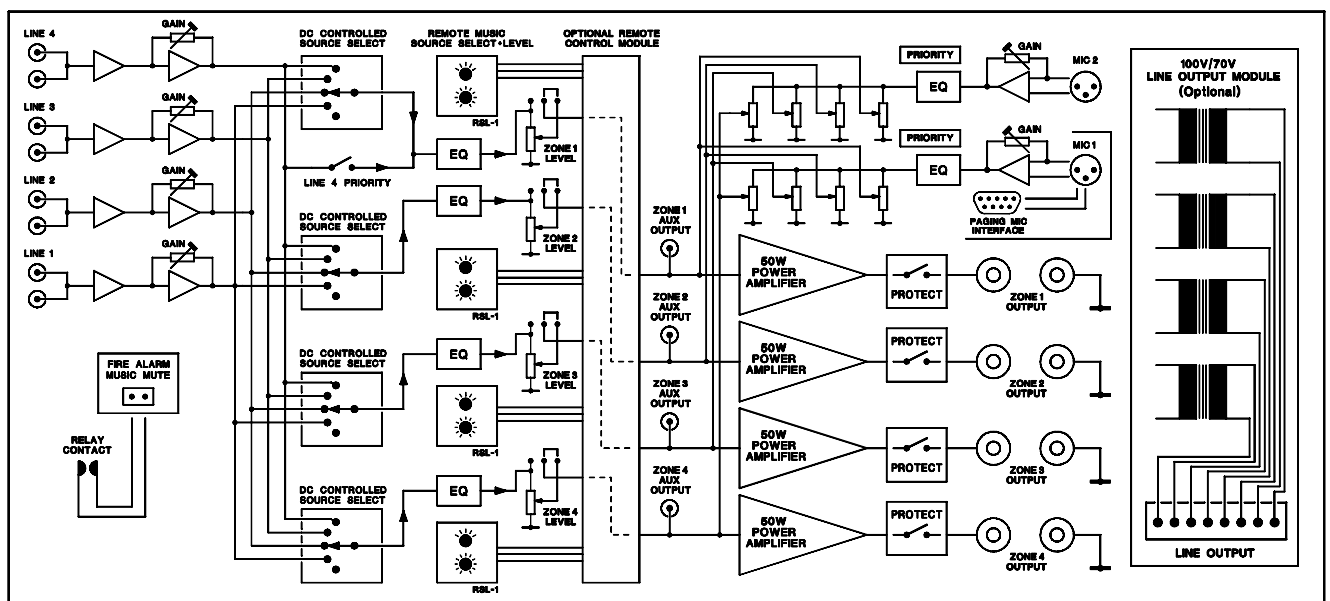

4 Installation

The Cloud 44/50 is suitable for mounting in a standard 19" equipment rack and occupies two units of rack space. Sufficient ventilation should be provided particularly where it is required to deliver a high output power for long periods of time; the unit draws cool air through the front panel and exhausts through the rear panel. The 44/50 is 300mm deep but a depth of 375mm should be allowed to clear connectors.

5 Music Inputs

The 44/50 operates in mono but is fitted with four stereo line inputs, which are internally mixed to form a mono signal. The line inputs are suitable for most music sources such as compact disc players, tape players and receivers etc. All the inputs are unbalanced and use RCA type phono sockets. The input impedance is 47k Ω .

6 Sensitivity & Gain Control

All four line inputs have a pre-set gain control on the rear panel adjacent to the respective input sockets. The input sensitivity can be varied from -12dBu (195mV) to +8dBu (2.0V). The pre-set gain controls should be set so that all the input signals operate at the same level within the 44/50 and the music level controls have an optimum range of control.

7 Music Control - Local or Remote

The music source and music level control functions can be operated from the front panel, or remotely when the optional REM-4 plug-in four channel remote control module is fitted and wired to a maximum of four RSL-1 control plates. This plate can be positioned up to 100 metres from the 44/50 and 2-core cable with overall screen should be used. Self-adhesive labels are provided to identify the signal source on both the 44/50 front panel and the RSL-1. The front panel mounted music level controls can be defeated if required, please refer to section 27 for full details. If preferred, the music source can be controlled from the 44/50 front panel with the music level only controlled remotely using the RL-1 remote level control. See section 21 for REM-4 fitting instructions and section 24 for remote level plate installation requirements.

8 Music Equalisation

Separate treble and bass controls are provided for music signals only on each of the four zones. This arrangement allows the installer to optimise the response of the music signals on a zone by zone basis where different acoustic properties require optimal equalisation adjustment. The equalisation controls are concealed behind the removable control panel secured to the front panel. Using the supplied Allen key, remove the four Allen cap screws which retain the control panel; the HF and LF equalisation controls are clearly marked and located below the music controls for the relevant zone. A flat frequency response can be achieved by positioning the slot on the control shaft in the horizontal plane. The music treble control (HF) has a range of ± 10 dB at 10kHz and the music bass control operates with a range of ± 10 dB at 50Hz.

9 Line 4 Priority

The Cloud 44/50 has a facility to allow fully automatic priority to a JukeBox or Spot Announce Player on Zone 1 only. A priority switch (concealed behind the removable plate on the front panel) is provided to select this facility. When the line 4 priority is in operation, Zone 1 will operate normally until a signal is detected on line 4 upon which the selected signal (usually background music) will mute, allowing the signal on line 4 to operate with priority. Once the signal on Line 4 ceases, the selected music signal will smoothly restore to its former level; the time taken for this restoration can be set at 3, 6 or 12 seconds by fitting the appropriate jumper (J5) on the upper printed circuit board. The factory default restoration time is 3 seconds. (See PCB layout on page 7)

10 Microphone Inputs

Two microphone inputs are provided and the microphone amplifier is an electronically balanced, transformer-less design configured for optimum low noise performance.

The input impedance is greater than $2k\Omega$ and is suitable for microphones in the 200Ω to 600Ω range. Inputs are via gold plated 3 pin XLR type connectors with latch and these are positioned on the rear panel. For balanced microphones, connect the cable screen to pin 1, the in-phase signal (+Ve) to pin 2 and the reverse phase signal (-Ve) to pin 3.

For unbalanced microphones, connect a wire link from pin 1 (ground) to pin 3 inside the XLR cable mounted plug; use pin 1 as ground (cable screen) and pin 2 as hot.

11 Paging Microphone

The Cloud CPM-4 four zone paging microphone is available as an optional accessory for the Cloud 44/50; the unit features zone selection switches which allow paging to all four zones in any combination and in addition, a 'call all' button is provided for convenient announcements to all zones.

The paging microphone is supplied with:

- 2 cable glands to accept 2-6mm cable
- 2 cable glands to accept 4-8mm cable
- 2 grommets
- A 9-core/female sub D-type cable assembly that should be fitted to the 44/50 motherboard.
- A Sub D-type male connector
- 4 M16 Nuts

NOTE: Should you wish to order a CPM-8 for use with the 44/50 then you must also order a 44/50 paging mic installation kit as it does not come as standard.

A zone can be accessed and reset with its relevant push/on push/off toggle switch. There is a jumper (J9) inside the CPM-4 that when positioned ON will configure the CPM-4 to automatically reset any accessed zone after an announcement has been made. The factory default for this jumper is OFF with J9 in the default position each zone must be reset manually after an announcement.

The CPM-4 can be configured internally to activate a pre-announcement chime if required. For applications where the speakers are located where the announcer cannot hear them, a chime sounder internal to the CPM-4 can be switched on or off as required to help avoid any announcements being made before the chime has finished.

We suggest that the CPM-4 should be wired using 2-core screened cable directly to the MIC 1 XLR input and 6-core cable with overall screen to the 44/50 paging microphone connector (as shown below).

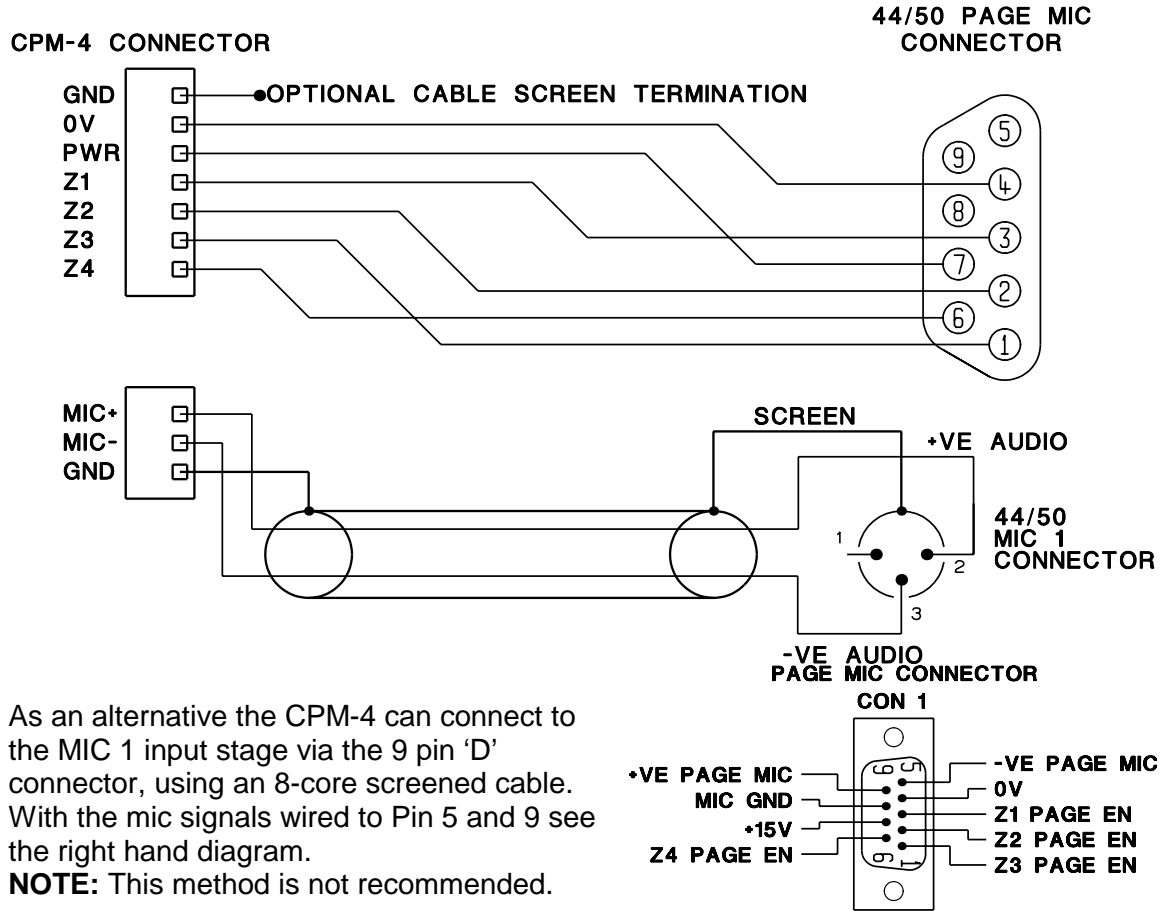

As an alternative the CPM-4 can connect to the MIC 1 input stage via the 9 pin 'D' connector, using an 8-core screened cable. With the mic signals wired to Pin 5 and 9 see the right hand diagram.

NOTE: This method is not recommended.

12 Connecting Multiple CPM-4s to the 44/50

When using more than one CPM-4 in a system, only audio and selection logic signals are connected in parallel. The wiring can be arranged in a wide range of configurations. For example the microphone cables can all be terminated at the mixer, 'daisy chained', or 'star' connected to a junction box. Any combination of these will work provided that the microphone zone access and audio terminals are connected in parallel. The total cable length in the system should not exceed 100m.

NOTE: The 44/50 can only power one CPM-4 any additional CPM-4 mics will require their own external power supply (CPM-PSU)

13 Microphone Gain Control

Pre-set gain controls are provided adjacent to the respective XLR input connector. The gain can be adjusted from 0dB to 60dB; this wide range of gain allows direct connection of high output devices such as radio microphones without the need for any additional attenuation. A high overload margin is maintained at all gain settings.

14 Microphone Equalisation

Two band equalisation is provided for both Mic 1 and Mic 2 and these pre-set controls are positioned alongside the input connector and gain control on the rear panel. The characteristics of the equalisation is optimised for the tonal correction of speech signals and the treble control (HF) provides $\pm 10\text{dB}$ at 5kHz with the bass control (LF) $\pm 10\text{dB}$ at 100Hz.

15 High Pass Filter

Both microphone channels pass through independent 3 pole high pass filters operating at 100Hz that provide effective attenuation of breath blasts and LF handling noises at a rate of 18dB/octave. The circuitry providing this feature is fixed and cannot be defeated.

16 Microphone Level Controls

Separate front panel mounted level controls for Mic 1 and Mic 2 are provided for each of the four zones. The level controls provide the user with a convenient means to operate either microphone at a suitable level in any zone; rotating any mic level control to the fully anti-clockwise position effectively turns the microphone off.

The microphone signals are routed directly to the power amplifier stage of the respective zone and mic signals are totally unaffected by the operation of the music controls. The Mic 1 & Mic 2 gain controls on the rear panel should be set at a level where it is not possible to have excessive gain even when the front panel level controls are fully clockwise.

For the benefit of the operator, self-adhesive labels are provided to identify the microphone channels and these can be fixed on the 44/50 front panel in the space provided, below and to the right of the power switch.

17 Microphone Priority

Fully automatic, voice operated priority is provided so that when a microphone is used, the music signals will attenuate by approximately 30dB; after the announcement, the music signals will restore smoothly to their former level. This 'microphone over music' priority can be defeated by configuring the internal jumper J10 located on the motherboard. Microphone priority is also provided and this allows announcements on the Mic 1 channel to have priority over any signal present on the Mic 2 channel, if you wish to disable this Mic 1 over Mic 2 priority then remove R160 from the 44/50 motherboard.

18 Auxiliary Outputs

Line level auxiliary outputs are provided to satisfy the occasional requirement to connect additional power amplifiers to any of the four zones, which may require more than the 50 watts provided. RCA type phono sockets mounted on the rear panel provide an output level of 0dBu (775mV) which should interface optimally with most types of power amplifier. If this auxiliary output signal is terminated to a balanced input stage, please remember to follow the manufacturers recommended procedure to unbalance the input stage. To reduce the risk of creating a 'ground loop', the additional power amplifier(s) should be positioned close to the 44/50 and be connected to mains power sockets that are on the same circuit.

19 Output Details

Binding posts for the four speaker outputs are provided on the rear panel these can accommodate flexible leads up to 2.5mm². The output connectors are not compatible with 4mm 'banana' plugs. Do not make any connections to the unit with the power cable attached and please remember that it is good practice to distance the output wiring from the input wiring and also use twisted pair cable for the speaker wiring.

20 100V or 70V Line Operation

The CXL-400 four-channel line transformer module is available as an accessory to the 44/50. It is rated at 40 watts per channel and optimally matches the Cloud 44/50 power amplifiers. The module is designed to fit inside the 44/50 chassis and may be configured for 70 or 100V operation by means of wire links on the PCB. Unless specified otherwise,

the module is configured for 100V output. Screw terminals are provided for the output connections.

The module can be used at frequencies as low as 40Hz without the risk of saturation. Operation at high input levels at lower frequencies may result in the transformer saturating and the amplifiers VI limiter operating.

21 Remote Music Mute - Fire Alarm interface

In certain circumstances, there may be a Local Authority or Fire Service requirement to mute the music signals via a fire alarm control panel in an alarm condition. The Cloud 44/50 provides a facility to mute the music signals only by connecting the two pole music mute connector to the contacts of a relay that is controlled by the fire alarm control panel. The two-wire connection should not be connected to any other circuit or voltage. In most instances, the fire alarm company will provide an auxiliary relay that is normally located close to the sound equipment rack.

All the microphone facilities operate normally when the music mute is operating.

22 Fitting and configuring the REM-4 Remote Control Module.

The REM-4 comes with three 35mm M3 hex spacers & four 3-pin screw terminal plugs.

1. Turn the power off and remove the mains cable
2. Remove the top panel
3. Remove the blanking plate from the rear panel
4. To the right of the large heat sink (looking at the 44/50 from the front panel) you will see three M3 fixing screws each next to a white arrow marked on the PCB, remove and retain these screws then fix three 35mm hex spacers in their place.
5. Position the 12-way socket of the REM-4 remote control module through the rear of the chassis and align the PCB over the three mounting pillars.
6. Secure the REM-4 with three M3 x 6mm (removed earlier)
7. Remove the four jumpers from the male header CON7 (see page 7), connect the 20-way ribbon cable to it and check that the connector mates with all 20 pins.
8. Mechanical installation of the REM-4 is now complete. Read the information below to configure the relevant jumpers

All jumpers can be found on the upper front PCB of the 44/50. Jumpers J1-4 are to the rear of the PCB and J6-9 to the front (see diagram below).

- **Jumpers J1-4** are associated with zones 1-4 and allow you to switch music source operation between either the front panel control ('FR' position) or a remote panel ('REM' position)
- **Jumpers J6-9** are associated with zones 1-4 and allow you to defeat front panel music level operation, passing total control to the remote control module.

ALL UNUSED REMOTE CONNECTORS ON THE 44/50 MUST HAVE PINS 1&2 WIRED TOGETHER

9. Now fit the top panel in place and the installation is complete.

23 Special Notes Regarding the use of the REM4

If the 44/50 is fitted with the optional REM4, the module must be connected to four remote control plates otherwise the music signals will be fully attenuated. If you propose to use any zone of a 44/50 (when fitted with the REM4) with no remote control, the respective 3 pole connector should be connected to the REM4 with a shorting link between pin 1 and pin 2. Please order extra connectors if you intend to operate the unit in this way.

24 Music signal processing PCB

When no remote control PCB (REM-4) is fitted, four circuit jumpers are fitted to the connector CON7; these jumpers must be removed before fitting the REM-4 module. If you wish to disable the music signals in any of the four zones, remove the relevant jumper from the connector CON7.

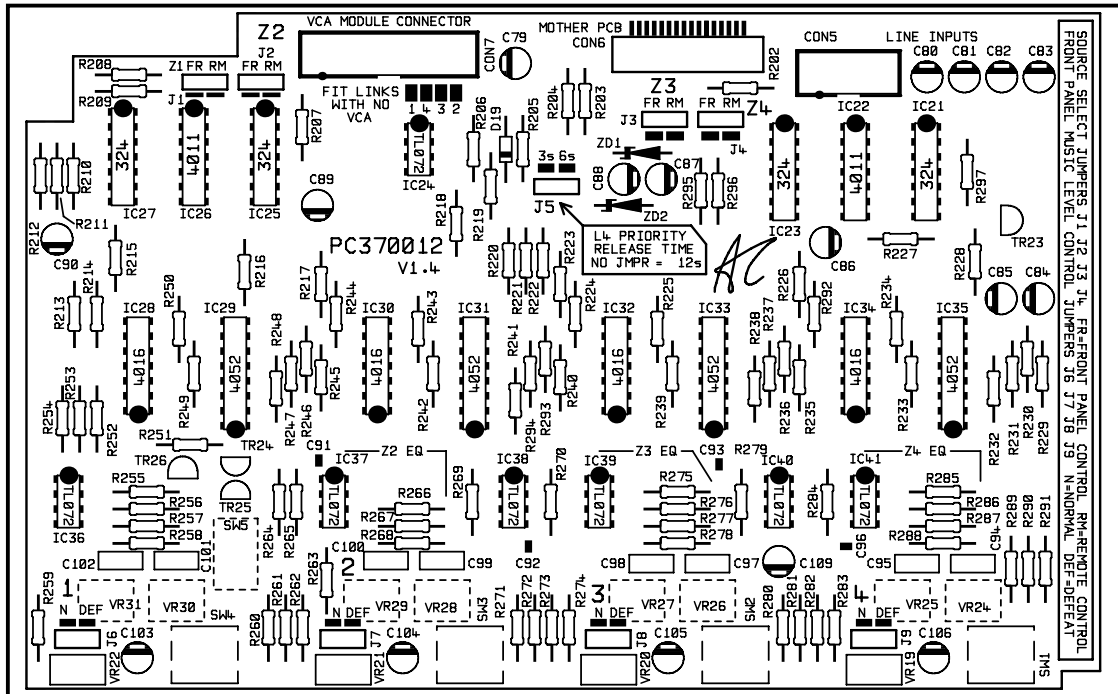

25 Installing RSL-1 or RL-1 Remote Controls

The remote control plates, RSL-1 and RL-1 are compatible with UK domestic electrical accessories and can be mounted onto a standard British flush or surface mounted 25mm deep back box. Two-core cable with overall screen should be used to connect the remote controls to the module mounted inside the Cloud 44/50. The circuitry uses the industry standard 'Thats 2150A' VCA chip to provide very low noise and distortion together with up to 90dB of attenuation.

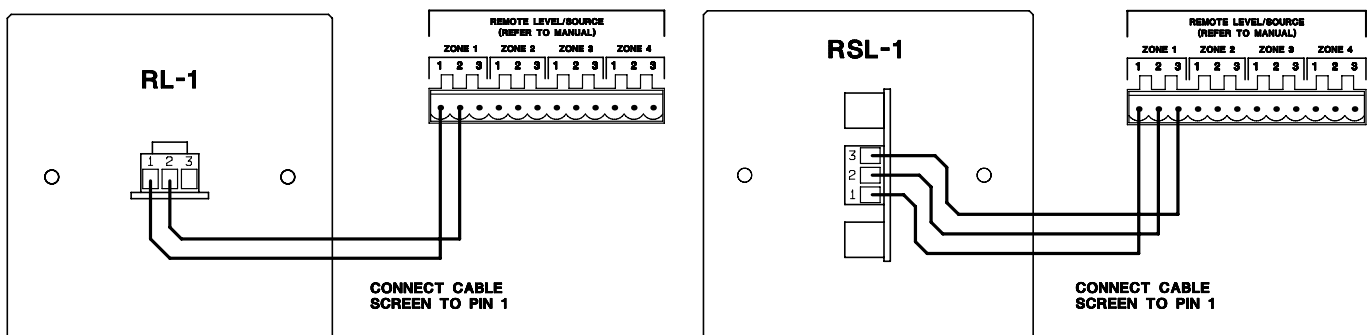

26 Controlling two or more zones with one RL-1

A single RL-1 can be used to control the music level of more than one zone, however, the extra load can cause the control to operate unevenly throughout its range; this has proved to be of little consequence operationally. When the RL-1 is used with the 44/50, wire it with single-core screened cable. It is assumed that the front panel music source select control will operate normally and the jumpers J1, J2, J3 & J4 will be configured for front panel (FR) control. Diagram on following page.

RL-1 Wired to Operate Two Zones

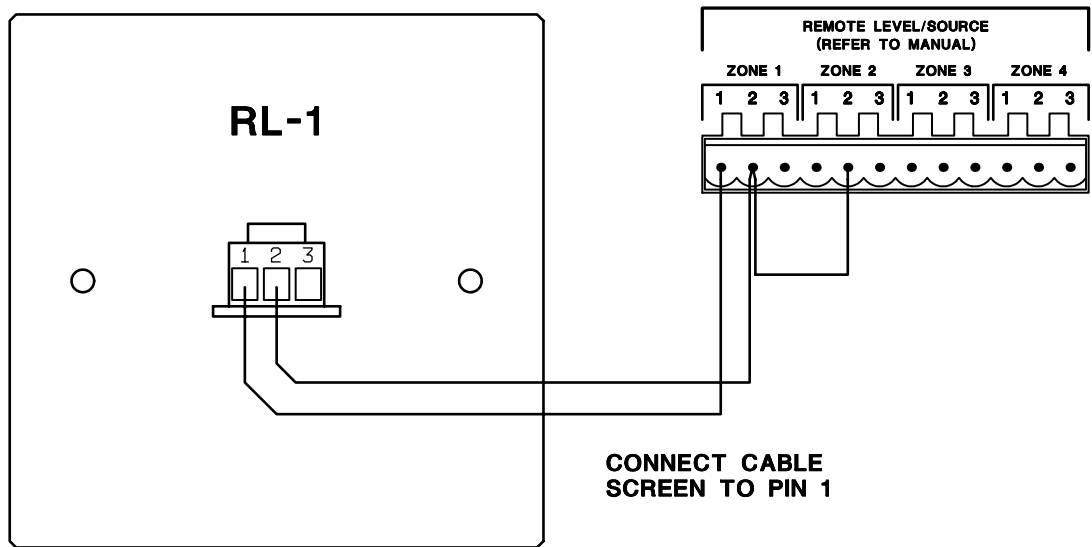

27 Controlling two or more zones with one RSL-1

A single RSL-1 can be used to control more than one zone; however, the three resistors fitted to the RSL-1 will have to be replaced with a different value. Where a single RSL-1 is used to control two zones, the resistors R1, R2 & R3 should be removed and replaced with three 3k3 types. With one plate controlling three zones, use 2k2 resistors and for all four zones, use 1k6 resistors. Where a single remote module is wired to control the level of multiple zones, the control will be loaded by the additional circuitry and will operate unevenly throughout its range; however, this has proved to be of little consequence operationally. Please order extra VCA 3 pole connectors if you propose to use this facility.

RSL-1 Wired to Operate Two Zones

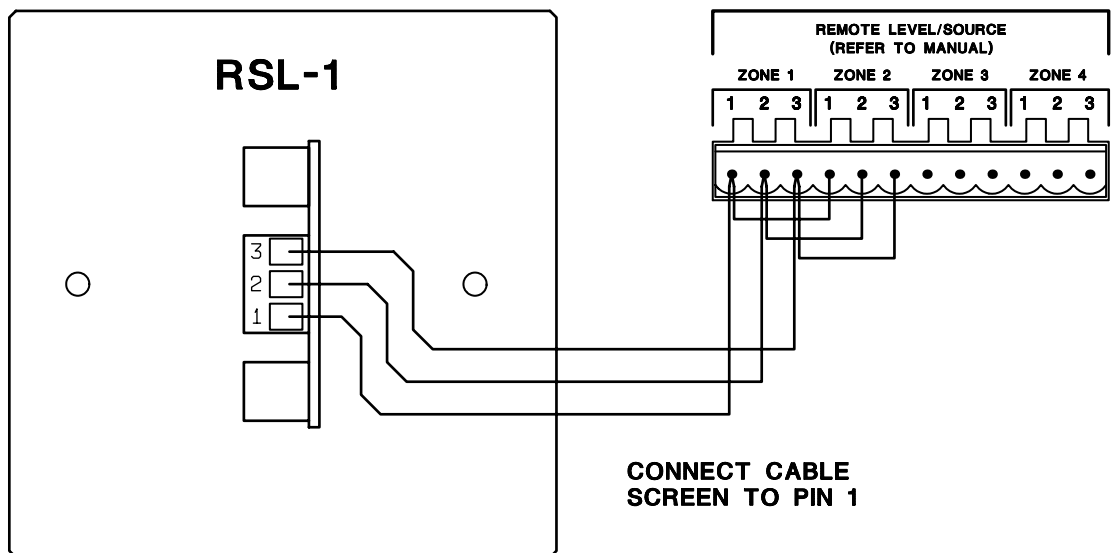

28 Front Panel Music Level Control Defeat.

When remote music level controls are fitted, the front panel mounted music level control will remain operational and under certain circumstances this can cause problems. Configuring the links on jumpers, J6 for Z1, J7 for Z2, J8 for Z3 and J9 for Z4 can defeat the relevant front panel mounted level controls. The position marked 'N' relates to normal operation; the position marked 'DEF' defeats the control and the audio signal bypasses the potentiometer. See the diagram on page 7 for jumpers locations.

29 Controlling the music functions using external DC control.

When fitted with the optional REM-4 module, the 44/50 can be used as part of an automated sound system by controlling the music level and music source by an external 0-10V DC voltage. The 3-pole connector normally used to terminate the RSL-1 control plate can be used to feed two separate control voltages into the 44/50. Pin 1 is a ground (0V) termination common to both control voltages; this should be connected to the technical ground (0V) of the voltage source. Pin 2 is the control voltage input for the music level and pin 3 is used to control the music signal source selection.

Level Control

A maximum gain reduction of 60dB can be achieved with a control voltage of +10V; the rate of attenuation is approximately 165mV per dB. A control voltage of zero realises unity gain (full volume), however, with no external connection to pin 2, an internal 4k7 resistor connected to the +15V power will 'pull up' the control voltage to provide maximum attenuation. The output impedance of the control voltage source should be low enough to overcome the influence of this resistor.

Source Select

Here are details of the source select control voltages (pin 3) required to switch the four line input signals:

Off	+6.00V
Line 1	+4.00V
Line 2	+3.25V
Line 3	+2.00V
Line 4	0.00V

With no external connection to pin 3, an internal 15k resistor connected to the +15V power will 'pull up' the source select control voltage and the 'off' position will be selected. The output impedance of the control voltage source should be low enough to overcome the influence of this resistor. If you require, you can permanently set the music signal to the Line 1 input by wiring a 20k resistor between pins 1 & 3 on the remote control connector.

If the control voltages are not isolated, there is a small risk of creating a 'ground loop' by linking the 44/50 ground with the ground of the equipment providing the control voltages; we suggest that all pieces of equipment be positioned in close proximity to each other.

30 EMC Considerations

The Cloud 44/50 fully conforms to the relevant electromagnetic compatibility (EMC) standards and is technically well behaved; you should experience no operational problems and under normal circumstances, no special precautions need to be taken. If the unit is to be used within close proximity to potential sources of HF disturbance such as high power communications transmitters, radar stations and the like, it is suggested that the microphone cable screen be connected to the shell of the XLR type connector, and the line input leads be kept as short as possible.

31 Technical Specifications

Line inputs

Frequency Response	20Hz-20kHz ± 0.5 dB
Distortion	<0.05% 20Hz -20kHz
Sensitivity	195mV (-12dBu) to 2.0V (+8dBu)
Input Gain Control	20dB range
Input Impedance	47k Ω
Headroom	>20dB
Noise	-90dB A weighted (0dB gain)
Equalisation	HF: ± 10 dB/10kHz LF: ± 10 dB/50Hz

Microphone Inputs

Frequency Response	100Hz / -3dB(filter) 20kHz ± 0.5 dB
Distortion	<0.05% 20Hz-20kHz
Gain Range	0dB-60dB
Input Impedance	>2k Ω (balanced)
Common mode rejection	>70dB 1kHz
Headroom	>20dB
Noise	-128dB EIN 22Hz-22kHz (150 Ω)
Equalisation	HF: ± 10 dB/5kHz LF: ± 10 dB/100Hz

Outputs

Auxiliary Outputs	775mV (0dBu) unbalanced (RCA phono sockets)
Speaker Outputs	50 watts rms/4 Ω 35watts rms/8 Ω via binding posts
100V line output	100 volts balanced – 250 Ω min load (optional module)
70V line output	70 volts balanced – 125 Ω min load (optional module)
Protection	VI Limiting, DC Offset, Thermal & switch-on delay
Cooling	Three speed DC fan

32 General Specifications

Power input	230V $\pm 5\%$ (115V $\pm 5\%$ available)
Fuse rating	230V – T3.15A 115V – T6.3A
Fuse type	20mm x 5mm class 3T 250V
Dimensions	482.60mm x 88.00mm(2U) x 300.00mm deep (+ con)
Weight	6.25kg net

This product conforms to the following European Standards:

EN 50081-1:1992

EN 50082-1:1992

EN 60065:1994



Safety Considerations

THIS UNIT MUST BE EARTHED. ENSURE THAT THE MAINS POWER SUPPLY PROVIDES AN EFFECTIVE EARTH CONNECTION USING A THREE WIRE TERMINATION.

Caution - Mains Fuse

TO REDUCE THE RISK OF FIRE, REPLACE THE MAINS FUSE ONLY WITH THE SAME TYPE AND RATING, WHICH MUST BE A CLASS 3, 250V TIME DELAY TYPE, RATED AT 3.15A WHERE THE MAINS INPUT VOLTAGE IS 230V. FOR A MAINS INPUT VOLTAGE OF 115V, THE FUSE SHOULD BE RATED AT 6.3A.

THE FUSE BODY SIZE IS 20mm x 5mm.

CAUTION - SERVICING

THIS UNIT CONTAINS NO USER SERVICABLE PARTS. REFER SERVICING TO QUALIFIED SERVICE PERSONNEL. DO NOT PERFORM SERVICING UNLESS YOU ARE QUALIFIED TO DO SO.

WARNING

TO REDUCE THE RISK OF FIRE OR ELECTRIC SHOCK, DO NOT EXPOSE THIS UNIT TO RAIN OR MOISTURE.
