

CLOUD VTX POWER AMPLIFIERS

MODELS VTX4120, VTX4240 & VTX4400

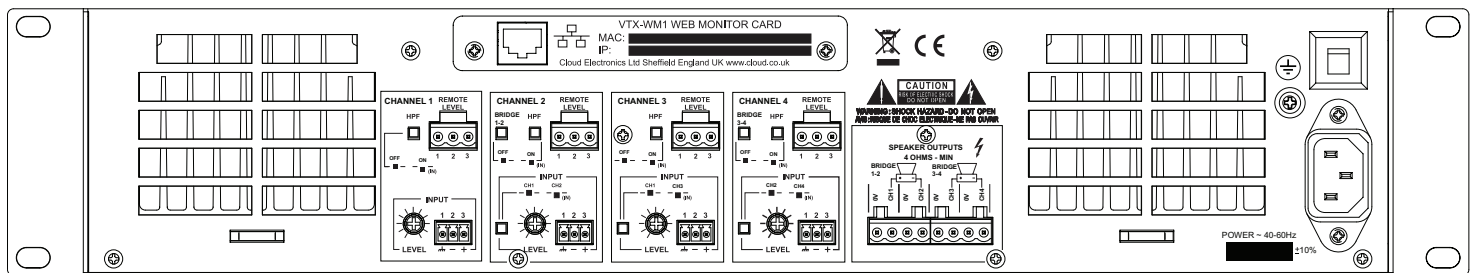
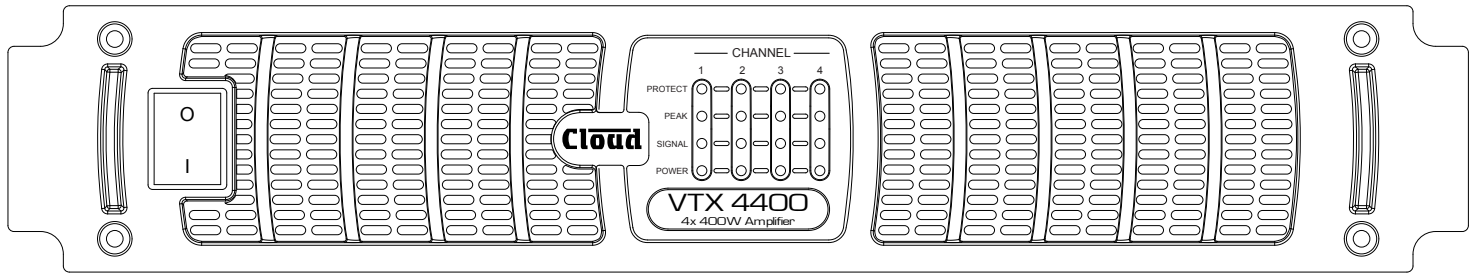

VTX Power Amplifier (fitted with optional VTX-WM1 web monitor card)

General Description

The Cloud VTX range of four-channel power amplifiers are intended for commercial and industrial public address and sound reinforcement applications where unquestionable long-term reliability is the primary consideration.

There are three models in the range:

MODEL	POWER
VTX4120	4 x 120 W
VTX4240	4 x 240 W
VTX4400	4 x 400 W

The amplifiers are designed to deliver their full rated power into loads down to 4 ohms for long periods of time. The circuit design includes clip limiting and switch-on delay, together with DC, thermal, short-circuit and reactive load protections. All models are built in a very solid steel 2U chassis, and employ variable-speed forced-air cooling.

Pairs of channels may be operated in Bridge Mode; rear panel switches are provided to enable this. Bridge Mode operation allows power outputs of double the normal rating to be delivered to a load of 8 ohms (minimum).

In addition to the power switch, the front panel is fitted with a set of four LEDs for each channel, confirming power status, signal presence, peak level and activation of amplifier protection circuitry. Rear panel controls are provided for individual channel gain trims, input routing (to configure the amplifiers for mono, dual stereo or four channel operation), Ch1/2 and Ch3/4 bridge mode, and per-channel high pass filters. The inputs are electronically balanced.

Standard options are the Cloud RL-1 remote volume control plates and Bose® EQ cards, either or both of which may be fitted to any or all channels. A further option is the VTX-WM1 web monitor card, which permits continuous external surveillance monitoring of the amplifier's performance on any computer via a standard Ethernet connection. See VTX-WM1 datasheet for full details.

- High power multichannel amplifiers for “install-and-forget” applications
- 4 x 120 W (VTX4120), 4 x 240 W (VTX4240) and 4 x 400 W (VTX4400) into 4 ohms
- Extensive protection against short-circuit and reactive loads, clipping, DC and overheating
- Chs1 & 2 and/or 3 & 4 may be operated in Bridge Mode
- Per-channel, front-panel LEDs for power status, signal presence, peak level and protection
- Balanced line level inputs with gain trim

- Configurable for 4 channel, dual stereo or mono use
- Per-channel switched hi-pass filter (18 dB/oct below 65 Hz)
- Optional VTX-WM1 card allows amplifier monitoring from any standard web browser
- Optional remote volume control (per-channel)
- Optional Bose® EQ cards (per-channel)
- 2U 19” rackmounting unit
- Forced-air cooling
- Five year warranty

Block Diagram - VTX Power Amplifier

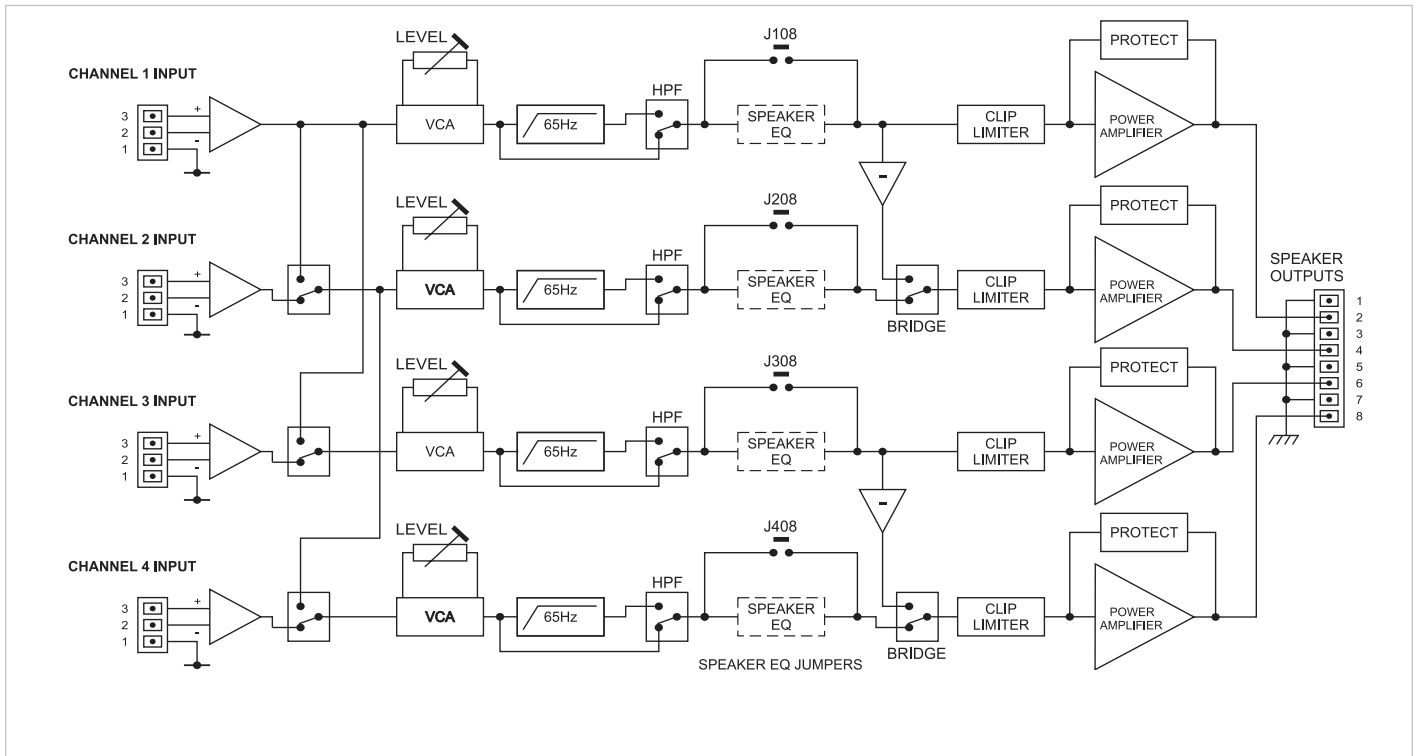

Input Routing

The input routing switches of the VTX range permit mono, stereo or 4-channel operation without any external parallel wiring. Some possibilities are shown below:

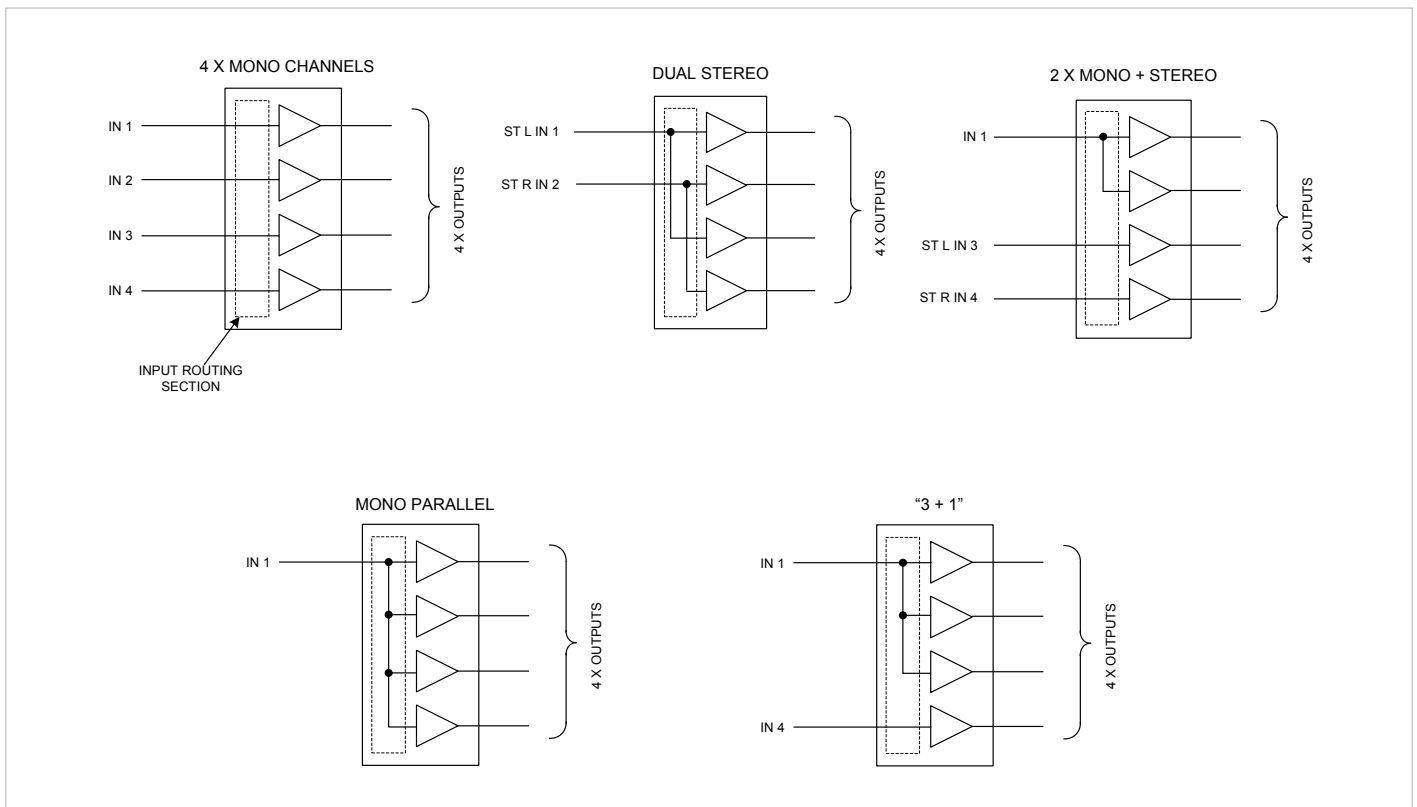

System Examples

The VTX amplifiers are suitable for any application that requires four separate channels of amplification. The Cloud CX263 zoner supports three zones, one of which may be stereo. In the example shown, Chs. 1 & 2 are used to drive stereo to Zone 1, while Chs. 3 & 4 are used for the mono signals to Zones 2 and 3 respectively.

Similar mono-stereo arrangements are possible with the Cloud CX163 and Z4II zoners.

Another useful application is to use a VTX amplifier to drive a stereo music system using a separate high-power sub-bass speaker system. An external crossover would be utilised to separate the low frequencies into a single mono feed, which could then drive channels 3 & 4 in bridge mode. Channels 1 & 2 would carry the normal left and right stereo MF/HF.

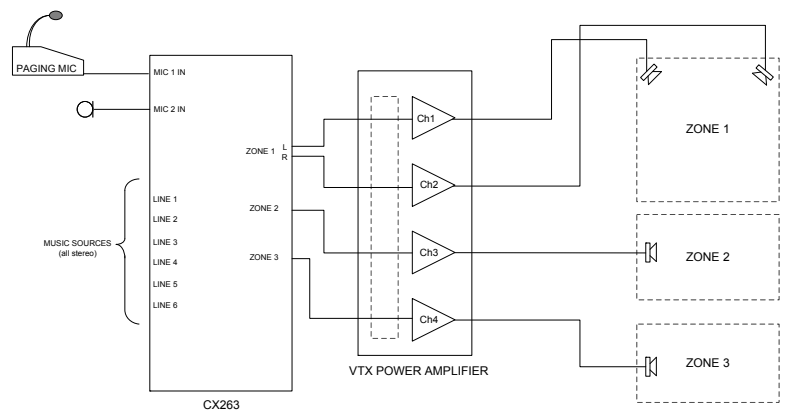

Graphs

VTX 4400 CH1 Frequency Response, 4 Ohm load, 400W Output

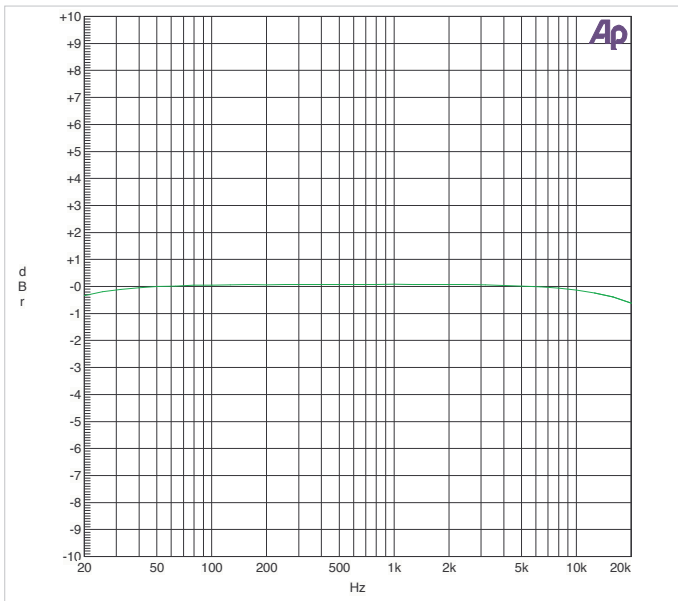

VTX 4400 ES 2 Typical Crosstalk, 4 Ohm load, 400W Output

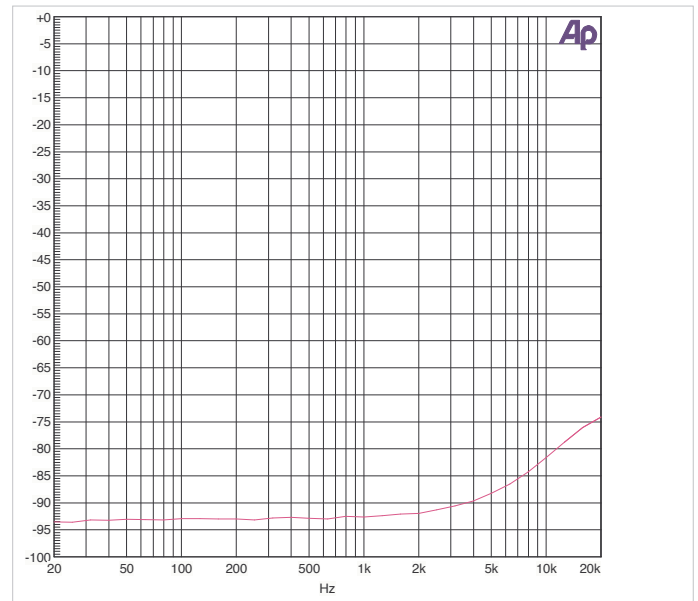

Technical Specifications

Performance

Output Power: Normal Mode, continuous sinewave, into 4 Ω.	
Power per channel, all channels driven:	VTX4120: 120 W VTX4240: 240 W VTX4400: 400 W
Bridge Mode into 8 Ω	VTX4120: 240 W VTX4240: 480 W VTX4400: 800 W
Frequency Response	20 Hz to 20 kHz, +/- 1 dB; (HPF bypassed)
High Pass Filter:	Switchable, -3 dB @ 65 Hz, slope 18 dB/octave
Distortion:	THD + N < 0.03% @ 1 kHz, 1 W output, 4 Ω load
Noise:	< 100 dB below full output power, 20 Hz to 20 kHz < 103 dB with 'A' weighting
Crosstalk:	-90 dB @ 1 kHz, -70 dB @ 10 kHz
Max. VCA attenuation:	> 90 dB

Inputs

Type & connectors	Electronically balanced; 3-pin 3.5 mm-pitch plug-in screw terminal connectors (4)
Max. sensitivity	0.775 V _{rms} (0 dBu)
Input Impedance	10 kΩ, balanced

General

Output Connectors	2-pin 5 mm-pitch plug-in screw terminal connectors (4)
Power input	230 V ± 10% (European version); 110 V ± 10% (US version)
Mains protection	By resettable rear-panel circuit breaker
Amplifier Protection	Clip Limiting, VI Limiting, DC Offset, Thermal & switch-on delay
Status Indicators	LED Indicators on each channel for Power, Signal Presence, Peak Level & Protection
Cooling	Force cooled; two mid-mounted variable speed DC fans
Dimensions (W x H x D)	482.6 mm x 88 mm (2U) x 416 mm (without connectors) 451 mm (with connectors)
Weight	VTX4120 - 13.8 kg (net); 15.8 kg (gross) VTX4240 - 16.5 kg (net); 18.5 kg (gross) VTX4400 - 20.0 kg (net); 22.1 kg (gross)

Architect's and Engineer's Specification

The power amplifier shall have four identical channels, and shall be available in three versions, differing only in the maximum power available. The three versions shall be capable of driving 120 W, 240 W and 400 W respectively, per channel into a 4 ohm load.

The amplifier's front panel shall incorporate an AC power switch, and LEDs indicating channel status, Signal Present, Peak Level and Protect status for each channel. The Signal Present LEDs shall illuminate at -26 dB below full output with respect to 0 dBu input sensitivity. The Peak LEDs shall illuminate at the onset of signal clipping. The Protect LEDs shall indicate activation of the output protection circuitry.

The amplifier shall be provided with one input per channel and be able to operate in the following configurations as a minimum: all channels independent, one input feeding all channels or two inputs feeding the amplifier channels in pairs for dual stereo operation. Signal level adjustment will be provided for each channel via a rear panel control permitting a range of operation from 90 dB attenuation (min.) to unity gain (max.). The inputs shall be electronically balanced and capable of operating with both balanced and unbalanced sources. The input impedance shall be not less than 10 kΩ (balanced). The input connectors shall be of Euroblock type. Each input shall be equipped with a high-pass 3rd order filter with a rear panel in/out switch. The turnover frequency of the filter shall be 65 Hz.

It shall be possible to retro-fit an optional surveillance card, which monitors the following per-channel parameters: load impedance, internal temperature, protection status, input signal level, level control setting and settings of input routing, bridge mode and high-pass filter switches. Amplifier fan operation shall

also be monitored. The surveillance card shall be fitted with an RJ-45 network socket, and all amplifier data shall be available by connecting this socket to a PC or Mac computer and the data viewed on a standard Web browser application.

It shall be possible to connect an optional remote control to any or all channels to allow adjustment of channel gain. The remote control connector shall be of Euroblock type.

It shall be possible to fit optional BOSE® Series II EQ cards to any or all channels.

Each channel output stage shall utilise Class AB operation with full DC crowbar protection. Each channel shall deliver its rated power from an input signal of 0 dBu with input level controls set at maximum. Output mute protection on power-up (4 sec) and thermal protection shall be provided. The amplifier will also be protected against short-circuits at the output, and excessive combination of output voltage and current. The amplifier outputs shall be on Euroblock connectors.

Cooling shall be by two forced air low-noise variable speed fans. The amplifier shall be built in a steel chassis suitable for mounting in a standard 19" equipment rack, and occupy two rack spaces.

The amplifier shall operate from either 230 V or 115 V AC mains, the intended mains voltage to be specified by the user at the time of order.

The power amplifier shall be the Cloud VTX4120 (120 W/ch), VTX4240 (240 W/ch) and VTX4400 (400 W/ch). The optional surveillance card shall be the Cloud VTX-WM1.